

## **Solar - RAPS Systems in the Daintree lowlands**

**– and an assessment of the effectiveness of pulse-desulphation technology for extending battery life.**

By Hugh Spencer and Paul Hollis

Cape Tribulation Tropical Research Station.

This project was initiated by the Australian Tropical Research Foundation and funded by the Queensland Department of Environment through Contract #31402.

December 2004

ISBN 09580755-1-4

Contents are copyright to the

**Australian Tropical Research Foundation**

PMB 5

Cape Tribulation Qld.

Australia, 4873

61 7 4098 0063

[austrop@austrop.org.au](mailto:austrop@austrop.org.au)

[www.austrop.org.au](http://www.austrop.org.au)

ABN 21 059 585 107

**Most batteries don't die, they are murdered.....**

**“More PV systems fail because of poor battery/charge controller performance than any other cause.”**

(from a fact sheet from Sandia Labs (USA) photovoltaic research section)  
(courtesy, Northern Arizona Wind and Sun)

**But....**

**a motivated householder is far more effective than a thousand controls!**

Our conclusion...

# Summary

Unarguably the **Daintree lowlands** constitute one of the **largest “non-intentional” solar powered communities in Australia**, if not the world with well over 100 installed units. They have a very difficult climate with a high level of unpredictability of sunshine hours, humidity that averages 80% throughout the year and about 4 meters of rain during the ”wet” - Dec to June.

This is a report on a study of the effectiveness of pulse de-sulphation technology on RAPS lead-acid storage batteries in the Daintree lowlands, in tropical north Queensland, and on the issues that affect the viability of such systems.

The study was initiated to determine whether or not de-sulphator technology was capable of slowing or reducing the rate of battery failure that has characterised the Remote Area Power Systems installed north of the Daintree River. Fifty-eight households were recruited for the study, with 5 dropping out because of changes to their RAPS systems which terminated their involvement in the project.

This study was commenced in May 2001 and was completed in October 2003.

Two types of de-sulphator were involved in the trial – a purpose built monophasic pulse de-sulphator capable of delivering pulses of over 1000A, and a prototype commercial “swept” pulse de-sulphator, with a lower current capability.

**The trial designed used a “split battery” approach**, wherein the battery bank was split into two equal sections (for 24V systems), with the de-sulphator connected across the first 6 cells, and the other 6 cells acting as a control. All cells in the battery string were in series, and so were subjected to the same charge and discharge conditions, and so **one half served as the control for the de-sulphator treated half**.

Both types of **de-sulphator** trialled **had a small positive effect** on the capacity of the commonest flooded lead acid batteries, however only 53% of the batteries tested showed improvement that could be unambiguously ascribed to the de-sulphator.

However, the **pulse de-sulphator demonstrated a very significant protective effect on the one gel cell system** in the trial, a result that shows considerable promise.

Perhaps far more significant than the trialling of the de-sulphator, **were the observations made on the installed systems as a result of the evaluation visits**, which together with observations gained through discussion with householders about their systems, gave us a considerable insight on the issues impacting battery health (and system capacity) in the area, and these **issues** are detailed in the report.

**Battery analysis technology such as the Celltron Conductance Analyser made this study possible, without it, it would have been impossible to assess battery health** (as **voltage and electrolyte specific gravity**, the two most commonly used indicators, convey **no information** about the **battery capacity**). For some reason there appears a great reluctance on the part of Australian battery manufacturers and installers to embrace it.

## **Summary of Issues**

As the Daintree is a non-intentional solar community, the interest, understanding and willingness to "learn to drive" the systems by the householders is largely lacking. Added to this is the poor initial design and installation of many systems that has compounded this problem.

- 1) **"Solar Paramedic"** Funding **urgently** required to allow the setting up of this local capability to provide preventative maintenance and diagnosis . We already have one person in the Cow Bay area with the capability and willingness to provide this service. **Preventative maintenance is alien to most householders, most maintenance is "reactive" in nature.** Such a service will greatly improve the performance and acceptability of renewable-RAPS in the area, and reduce demands for mains connected power.
- 2) **Solar charge regulators** are probably **responsible for** many of the **catastrophic battery failures** observed during the study, through being wrongly set up, their inability to perform boost charging (under cloudy conditions) , and limiting the charge available to the batteries

during periods of intermittent sun. Most RAPS system users use more power than supplied by the solar array.

- 3) **Solar charge regulators**, if used, should be:-
  - a) **set up correctly** (correct equalisation voltage)
  - b) **fitted with bypass switches** (with warning light)
  - c) **Only used during periods of occupier vacancy**, unless power draw is significantly less than array input power (which could lead to overcharging).
  
- 4) **Maximum power point trackers** (MPTT's or **Maximisers**) should be mandatory in all systems as these can **increase the efficiency** of the solar array by up to **30%** (especially under conditions of low battery voltage and lightly overcast skies) and **they replace solar charge regulators**.
  
- 5) **Battery banks** larger than necessary **can't be maintained** properly charged under conditions of erratic solar availability. Most battery systems in the study **failed because of chronic under charging**.
  
- 6) **Equalisation - Failure to equalise** battery banks regularly (or at all) is the **major direct cause of battery failure** in the Daintree. Causes:-
  - a) Solar regulator incorrectly set up
  - b) Solar regulator – timed equalisation periods don't correspond with solar power availability.
  - c) Householder ignorance of the importance of equalisation.
  - d) **No Amp-Hour meters** (lack of appropriate metering).
  - e) Reluctance to run generators for the time taken to equalise batteries.
  
- 7) **Battery types**
  - a) Standard flooded Pb-Sb cells are commonest but sensitive to maltreatment.
  - b) **Tubular plate Pb-Ca cells are more robust** in this environment.
  - c) Gel Cells (Pb-Ca) probably unnecessary with current system design, and delicate.
  - d) "Hydrocap" catalytic H-O recombining caps highly recommended to reduce watering maintenance requirements.

- 8) Use of **hydrometers** does NOT detect changes in capacity of batteries and can, by introducing contaminants, can damage batteries and are **essentially useless** and should be discouraged. The use of an **Amp-hour meter is far more valuable**.
- 9) **Metering**. Most Daintree systems have **very poor or inaccessible and/or conflicting metering**, which has a **major negative impact** on the householder's **ability to "drive" their RAPS systems** properly.
- 10) **Amp-Hour meters – solar "fuel gauges"**
  - a) **Absolutely essential** for managing any solar energy system, however most available designs are still fairly basic and only one design compensates for battery efficiency.
  - b) **Peukeut's relationship** – the **capacity** of batteries **depends on rate at which energy is taken out**. Higher the rate, the lower the capacity. A battery discharged at 10 A has in general **twice the capacity** of the SAME one discharged at 100A.
  - c) Amp-hour meters must take this into consideration – but most present designs don't.
  - d) Almost completely missing from systems in the Daintree (but crude "battery %" gauges are common).
- 11) We suggest a **centrally** (in house) **located, easy to read meter** design with push-buttons to access each of the important measurements, as well as having warning indicators, and the ability to stop and start the generator remotely.
- 12) **Data loggers** are potentially useful for maintenance, but **modem-connected loggers are a recipe for disaster** (as they can lull householders into a false sense of security, and are a major additional cost).
- 13) **Installers**: "Just another business" for most.
- 14) Small visitors. **Gekkos and insects** are a **major cause of failure** for inverters and solar charge controllers. **Fungus and water condensation** destroy electronics and casings. "Visitor proofing" and a dry enclosure is essential.

**15) Gensets:**

- a) **Noise** – major neighbourhood issue, **not addressed** by D-RAPS program.
- b) 3000 rpm generators commonest (petrol/diesel) - noisy
- c) 1500 gensets (diesel) uncommon. Usually much larger, quieter and more fuel efficient.
- d) Remote electrical start/stop essential**
- e) Alternators should be **tropic proofed** before installation (4-pole installations)
- f) **Water cooled gensets quietest**, and can provide household hot water boost
- g) Appropriately designed gen-shed, can dry laundry and provide hot-dry storage and even hot water - a significant increase in efficiency.

**16) Chargers**

- a) **linear chargers** should be **replaced by switchmode chargers** (more efficient, higher charge current and accurate battery charging). Technology is still fairly new.

**BUT**

- 17) **DC generators** should replace AC generators (modern inverters can handle very large loads at high efficiency), high fuel efficiency, no changeover problems, **no separate charger needed**. **It all depends on the design configuration chosen.**

- 18) **Energy conservation** is a major mechanism for **increasing effectiveness** of RAPS system effectiveness but:-

- a) **"If there's a socket in the wall, let's see how many things we can plug into it"**
- b) **Little understanding by householders** of conservation principles and techniques.
- c) Most **energy efficient devices** are **not "tropics" friendly** (compact fluoro's die fast)
- d) Timing of use of energy hungry appliances to periods when generator is running.
- e) **Appropriate choice of appliances**- inadequate/inappropriate appliance design.
- f) **Phantom loads** (power consumed by appliances when "off") is becoming a **major** problem which **can consume 20% of available energy** in some instances.
- g) Solution: **"Turn everything OFF at the wall** when finished using it" (assisted by having **power-on indicators on wall sockets**)
- h) Solution: **Householder education** - by "packages" as well as community discussion groups. Australian Greenhouse Office solar audits (Cool Communities Program)??

**19) Solar Arrays**

- a) **Adjustable angle roof - array mounts** essential to allow 3x yearly optimisation of array output by householder.
- b) **Mechanical Trackers can add up to 30% to array outputs** but need improved and more reliable designs.
- c) **Tower or pole mounting of arrays** in middle of house can give full solar exposure without additional tree clearing. Pole is cheaper than clearing.

## 20) Changes in technology

- a) **Automation** of RAPS systems – we suggest a scheme, but track record elsewhere of automated systems is not good.
- b) **High voltage RAPS systems** – the trend is to higher voltages which offer higher system efficiency (although battery efficiency remains much the same) and cheaper system components.
- c) Improvements in solar cell technology in conjunction with mechanical trackers and MPPT's have the potential to offer up to a **4x increase** in array output, making pole mounted arrays in the future a practical reality (even if presently pricey).

## Future.

• **Battery efficiency** will stay about the **same**, but **reliability will increase** with better battery management technology. **De-sulphators** will have a place in this with some (Gel-AGM) batteries **as a form of insurance against catastrophic failure**.

• Use of **conductance analysers** will allow **battery faults to be diagnosed** long **before** they start to materially **affect battery performance**, and permit restorative action to be taken. ("Solar paramedics" as a **community-based** resource)

• Use of **amp-hour meters** must become **mandatory**.

• Use of **Maximisers** must become **mandatory** which will push their currently high prices down to be similar to normal controllers..



- Appropriate and in-depth **education of householders** **MUST** be carried out **when system is installed**, especially issue of **”phantom load”** energy waste..
- **Increases in efficiency** of equipment will assist in **reducing solar ”footprint”**.
- **There is a significant market for Australian produced solar equipment** – particularly electronically controlled DC generators, Maximisers, solar trackers, racks, compensating amp-hour meters and central metering equipment, as well as automated system controllers. Associated with this is the need for some form of standardisation of signals from the various pieces of equipment so a common metering centre can access them. The loss funding for of ACRE (Cooperative Research Centre for Renewable Energy) based at Murdoch University (WA) has been a major retrograde step.
- **There is a significant market for real improvements in appliance efficiency** and longevity (especially in the wet tropics), tropic proofed compact fluorescent lights, use of Color-Bond for all whitegoods carcasses, more efficient HC (hydrocarbon) refrigeration and better insulation for refrigerators. Elimination of ”instant-on” designs.
- Mandatory provision of indicator lights on AC power outlets. (used to be common many years ago!).
- A formal mechanism for feedback to industry and government agencies, on the state and issues concerned with renewable RAPS systems.

## Acknowledgements

Bill Chinnick, of HotWire in Adelaide, who first introduced us to the virtues of the Celltron CTM-100 Conductance analyser, and who supplied the samples of commercial de-sulphators used in the study. Stuart Wilkinson of AREL for valuable discussions, and to tolerance of the residents of the Daintree who have had their privacy ”invaded” on many occasions during the course of the study. Grant Behrendorff of ”Bushlight” (Alice Springs), Max Enfield of ”Planetary Power” (Herberton) and Chris CS AutoElectrical And Diesel, Cairns, gave very helpful comments on the text. Ray Miller (Ecco2sol global energy solutions) also critiqued the text.

## Table of Contents

|   |    |
|---|----|
| Introduction.....   | 1  |
| History.....  | 4  |
| Basic Daintree RAPS system parameters.....  | 4  |
| Basic Solar RAPS system configuration.....  | 6  |
| Trial design.....   | 7  |
| Battery capacity.....   | 8  |
| Measuring Battery Capacity.....   | 9  |
| Relationship between conductance and state of charge.....                         | 13 |
| De-sulphator.....   | 13 |
| Battery Connections.....  | 15 |
| Package.....  | 15 |
| Installation.....   | 15 |
| The Survey.....   | 16 |
| Trial population.....   | 16 |
| Other involvement.....  | 16 |
| Assessment procedure.....   | 16 |
| RESULTS.....  | 17 |
| Effectiveness of monophasic high current de-sulphator design.....                 | 17 |
| A particular case – Gel Cells.....  | 21 |
| Examples of battery behaviour encountered.....                                    | 23 |
| Relationship between PV array power and battery capacity and battery failure..... | 26 |
| Details of systems encountered during the study.....                              | 27 |
| ISSUES.....   | 31 |
| Cultural/sociological issues.....   | 31 |
| System Configurations.....  | 32 |
| Serial configuration.....   | 33 |
| Switched system.....  | 33 |
| Parallel system.....  | 33 |
| Choice of Battery type.....   | 34 |
| Battery Sizing.....   | 35 |
| Solar arrays.....   | 36 |
| Array angle.....  | 36 |
| Trackers.....   | 38 |
| Solar Array Exposure.....   | 39 |
| Charging.....   | 39 |

|  |           |
|--|-----------|
| Solar charge Regulator.....                          | 39        |
| Bypass switches.....                                 | 40        |
| Solar Maximisers (Maximum Power Point Trackers)..... | 41        |
| Low Voltage Cut-out.....                             | 42        |
| High Voltage Cut-outs.....                           | 42        |
| Chargers.....  | 42        |
| Charger size.....                                    | 44        |
| Battery Equalisation.....                            | 44        |
| Gensets.....   | 45        |
| Genset Design.....                                   | 45        |
| Remote electric start.....                           | 46        |
| DC Generators.....                                   | 46        |
| Noise.....   | 47        |
| Inverters.....                                       | 48        |
| Metering.....  | 48        |
| Meters.....  | 49        |
| Amp-hour meters.....                                 | 49        |
| A suggested metering system.....                     | 51        |
| Metering objectives.....                             | 52        |
| Data Loggers.....                                    | 52        |
| Installers.....                                      | 53        |
| Unwanted visitors.....                               | 53        |
| Gekkos.....  | 53        |
| Visitor Exclusion.....                               | 53        |
| Fungal Growth.....                                   | 54        |
| Co-generation.....                                   | 55        |
| Energy Conservation and Demand-side Management.....  | 56        |
| Inappropriate/Inadequate Appliance design.....       | 58        |
| <b>Solar “paramedic”.....</b>                        | <b>59</b> |
| Future.....  | 59        |
| References.....                                      | 64        |
| <b>Appendix 1 De-sulphator design and testing</b>    |           |
| De-sulphator design and testing.....                 | 65        |
| Pulse measurement technique.....                     | 65        |
| Measured di/dT.....                                  | 68        |
| Commercial de-sulphator.....                         | 69        |

|   |    |
|---|----|
| <b>Appendix 2</b> Illustrations of representative Daintree Installations..... | 70 |
| <b>Appendix 3</b> Maximum Power Point Tracking (MPPT) - “Maximisers”.....     | 74 |
| <b>Appendix 4</b> Other techniques for battery conservation.....              | 78 |
| <b>Appendix 5</b> Suggested Design Parameters for a Control System.....       | 81 |
| <b>Appendix 6</b> Menu Driven Program for Trace inverter                      |    |
| <b>Appendix 6b</b> Menu Driven Program for Plasmatronics Solar Controller     |    |
| <b>Appendix 7</b> Map of the Daintree Lowlands                                |    |



## Table of Figures.

|          |  |    |
|----------|--|----|
| Fig. 1   | This is a electron microscope picture of a battery positive plate.....   | 1  |
| Fig. 2   | This is a electron microscope picture, magnified 549 times, of a 6 month old battery positive plate.....   | 2  |
| Fig. 3   | This battery positive plate, magnified 554 times, has been in operation on an emergency vehicle equipped with a desulphation device for 11 months..... | 3  |
| Fig. 4   | Basic layout of a conventional Photovoltaic Remote Area Power system (RAPS).....   | 6  |
| Fig. 5   | Test arrangement for the trial.....  | 7  |
| Fig. 6   | Peukeut plot of change in cell capacity (in ampere-hours) vs discharge rate.....   | 9  |
| Fig. 7   | Simplified arrangement for measuring AC conductance of a cell or battery.....  | 10 |
| Fig. 8   | Celltron Conductance analyser.....   | 12 |
| Fig. 9   | Change in conductance as a function of the discharged state of the battery.....  | 13 |
| Fig. 10  | Packaged desulphator, ready for installation.....  | 14 |
| Fig. 11  | Plot of conductance changes in the test battery population (monophasic).....   | 18 |
| Fig. 12  | Plot of conductance change in the test battery popululation (commercial).....  | 19 |
| Fig. 13  | Original plot from preliminary report.....   | 20 |
| Fig. 14  | A time series indicating the effect of the desulphator fitted to the only set of GEL cells in the study, 21  |    |
| Fig. 15  | An example of a well maintained battery of flooded Pb-Acid cells.....  | 23 |
| Fig. 16  | A well maintained set of Century-Yuasa SSR700 tubular plate batteries.....   | 24 |
| Fig. 17  | System degradation An example of originally well maintained AS1100.....  | 25 |
| Fig. 18  | Ratio between the peak PV array power (in watts) divided by the installed battery capacity in AH....   | 26 |
| Fig. 19. | The distribution of peak power of arrays.....  | 27 |
| Fig. 20  | Distribution of solar cell types encountered in the survey,.....   | 28 |
| Fig. 21  | Battery types encountered during the survey.....   | 28 |
| Fig. 22  | Distribution of regulator tpest.....   | 29 |
| Fig. 23  | Distribution of charger types.....   | 29 |
| Fig. 24  | Distribution of Inverter types.....  | 30 |
| Fig. 25  | Distribution of genset capacities.....   | 30 |
| Fig. 26  | The 3 configurations employed in RAPS systems.....   | 32 |
| Fig. 27  | Effect of PV array angle versus month on incident solar radiation.....   | 36 |
| Fig. 28  | Elevated solar arrays.....   | 38 |
| Fig. 29  | Peukeut plot of cell capacity (in ampere-hours).....   | 50 |

## Appendix 1 De-sulphator design and testing

|  |    |
|--|----|
| Fig 1 Basic schematic of the desulphator.....                  | 65 |
| Fig. 2 Current pulse measuring set up for the desulphator..... | 66 |
| Fig. 3 Oscilloscope trace of the desulphator pulse.....        | 67 |
| Fig. 4 Current measuring set up (commercial de-sulphator)..... | 69 |

## Appendix 2 Illustrations of Daintree Installations.

|  |    |
|--|----|
| Fig 1 A basic system employing AS1100 batteries.....                     | 70 |
| Fig 2. A common style of installation.....                               | 71 |
| Fig 3 Solar array at the Cape Tribulation Tropical Research Station..... | 72 |
| Fig 4 Battery located under a shed floor.....                            | 73 |

## Appendix 3 Maximum Power Point Tracking

|   |    |
|---|----|
| Fig 1. Current voltage relationship of a nominal solar panel array..... | 76 |
|---|----|

## Appendix 4 Other techniques for battery conservation

|   |    |
|---|----|
| Fig. 1 Built in hydrometer and thermometer..... | 78 |
| Fig. 2 A battery driven bubbler.....            | 79 |

## Appendix 4 (no image)

## Appendix 5

Menu Driven Program for Trace inverter

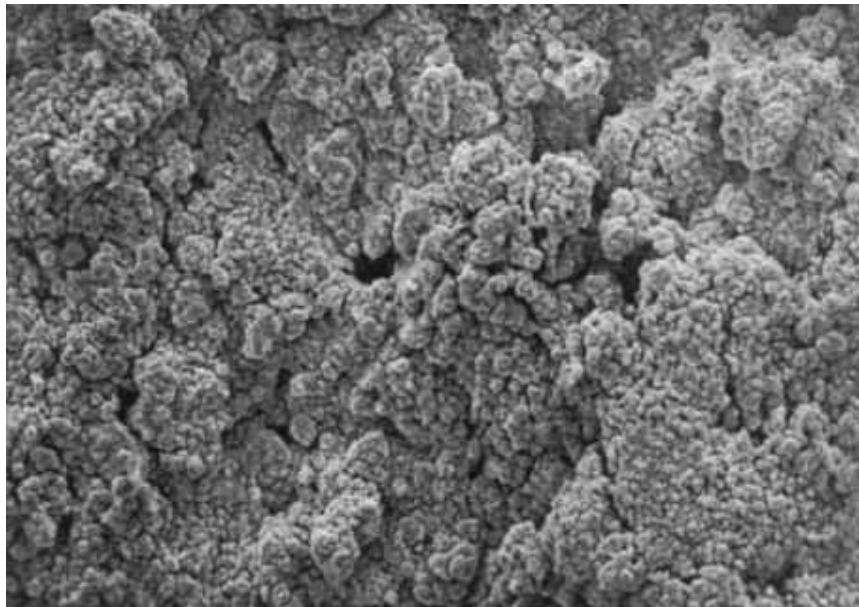
Menu Driven Program for Plasmatronics PL series

## Appendix 6

Map of the Daintree Lowlands

## Introduction

Lead acid batteries are the storage mainstay of renewable energy systems. The technology has been in existence for over a century, and except in details, is essentially unchanged. Basically it consists of two plates of lead bathed in dilute sulphuric acid. Charging (passing an electric current between the plates) converts the plate on one side to lead dioxide and the other plate to spongy lead. Discharging converts both plates to lead sulphate, and in the process generates an electric current in an external circuit. This cycle can be repeated for hundreds and in some cases thousands of times before there is no more lead sulphate available to be converted, at which time the battery is totally useless.

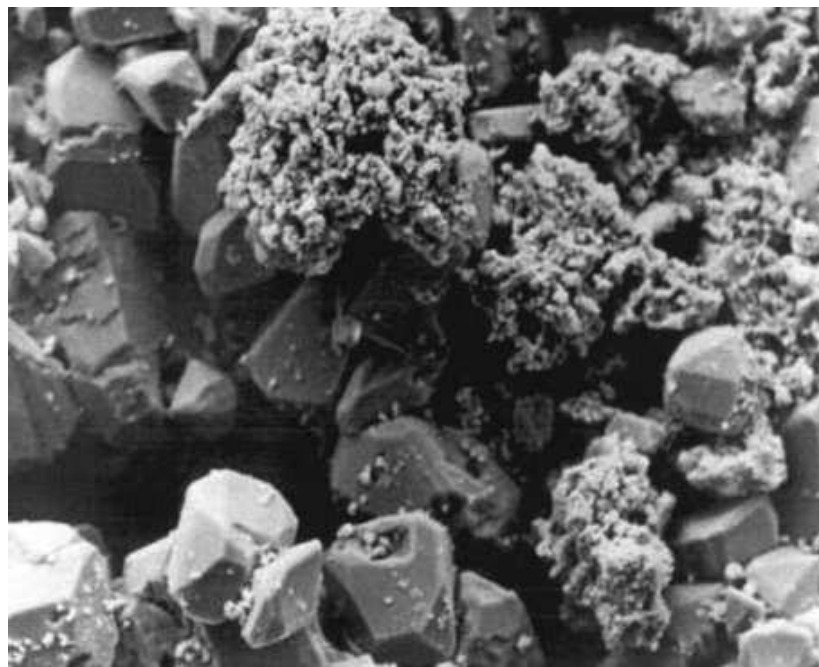


<http://www.vdcelectronics.com/desulphation.htm>

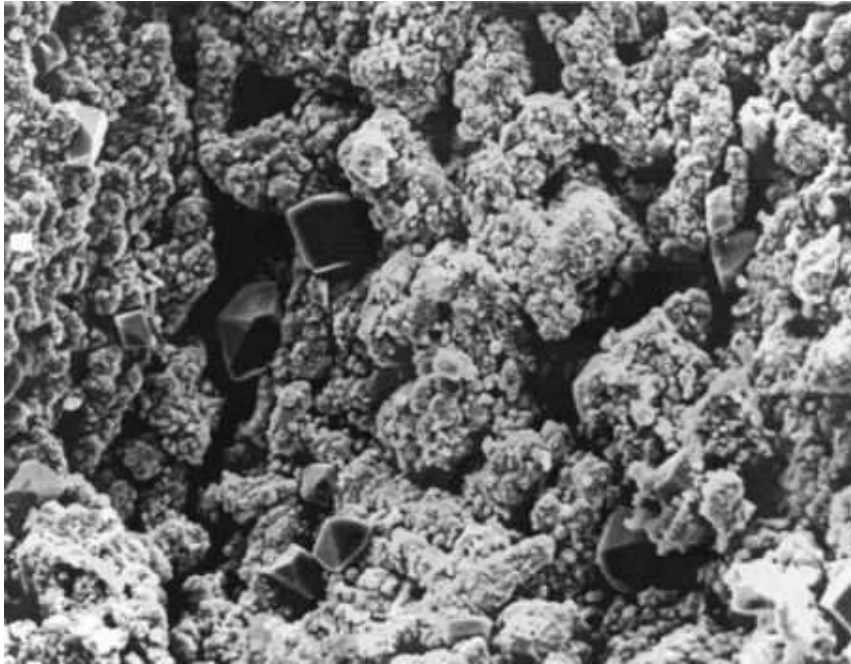
**Fig 1** An electron microscope picture of a new battery positive plate (magnified 558 times) that has never been exposed to electrolyte. Compared with the photographs below you can see the complete absence of sulphate crystals on the battery plate and the healthy "sponge lead" appearance of the plate. Without the addition of the electrolyte, the natural chemical reaction resulting in sulphation has not yet begun.



**De-sulphation** technology for lead-acid batteries has been in existence for some 15 years, and is based on the concept that a brief high-current pulse applied to a lead acid storage cell is able to prevent the accretion of lead sulphate crystals (produced as part of the discharge process) into large crystals or groups of crystals that become disconnected from the active electrode of the cell, and hence no longer contribute to the storage capacity of the battery. How this occurs appears to be highly speculative although it is postulated that the pulse, if strong enough and with a fast enough onset time, will cause the molecular bonds of the lead sulphate ( $\text{PbSO}_4$ ) to resonate, in a manner analogous to a guitar string being plucked, and this reduces the tendency to produce larger crystals. Whatever the mechanism, these electron micrographs of dismantled cell plates which have been operated with a de-sulphator, show a substantially smaller crystal grain size than those operated without one.



**Fig 2** This is an electron microscope picture, magnified 549 times, of a 6 month old battery positive plate used in an ambulance. Given the amount of sulphation, this battery has already reached the end of its service life. Note the large sulphate crystals on the battery plate and the severe erosion of the sponge lead plate material. This battery was never de-sulphated.



**Fig 3** This battery positive plate, magnified 554 times, has been in operation on an emergency vehicle equipped with a de-sulphation device for 11 months. Note the presence of a few large crystals, but otherwise the appearance is similar to the new plate. The battery was performing well, but was removed and torn down so as to carry out this electron microscope inspection.

Thus the anticipated effect of the de-sulphator on battery capacity would be that the reduction in crystal size and improvement in the resultant crystal connectivity to the active plates, should be reflected in changes (increase) in battery capacity.

Lead acid battery chemistry is in fact exceedingly complex and it is only in the last 10 or so years that a fuller understanding of the conditions involved in charging and discharging are transforming our understanding of their capabilities and limitations.

Each battery type has a set of unique attributes that can have a major effect on its performance under different operating conditions. This variability in battery type and chemistry greatly complicates studies such as this one, but as de-sulphator technology is really only beginning to be investigated, studies such as this one help establish the parameters for their appropriate application.

## History of Renewable Energy in the Daintree

As the settlers in the Daintree lowlands do not have access to grid electricity supply they have of necessity been obliged to adopt some form of Remote Area Power Supply (RAPS) to supply their electricity energy wants. Prior to 1994, a very few had primitive photovoltaic based RAPS, the remainder made do with generators, or did without (hoping all the time that grid connected electricity would be supplied to the area) (Spencer 1994). The undertaking by the Goss Queensland Labor Government (1994), and continued by the current Beattie Labor Government, to provide what were in effect grants to householders resident in the area for the purchase of renewable energy based RAPS systems (D(aintree)RAPS scheme), has greatly aided the uptake of this technology. In effect the Daintree lowlands constitutes one of the **largest “non-intentional” renewable energy settlements in the world**; (“non-intentional” because to date most people adopt a renewable energy RAPS system out of a commitment to living “lightly on the planet”, whereas in the Daintree it was “RAPS or nothing” and as a result much of the commitment to “making it work” is lacking.)

This “non-intentional” issue becomes critical in the assessment of the results of the trial.

### **Basic Daintree RAPS system parameters**

Systems installed in the Daintree lowlands derived from the initial DRAPS scheme introduced in 1995 (Enfield 2001), and many of these were installed in a rush during the first year of the scheme. As there was an almost total lack of expert solar installers in the area, companies involved in marine electrics and battery sales moved into the new market, and not surprisingly most of these had to learn their skills on the job.

Besides, the funds available through the scheme were just sufficient for a basic system for most householders. As a result most installed designs might be considered “cut and paste” approaches – with the designs showing no apparent awareness and understanding of the issues that constrain system design in the area. Worse, it has transpired from discussion with several installers, that most householder’s demanded that their systems cost no more than the rebate allowed (approximately 15,000 dollars average) and they were

not prepared to invest their own money into the systems.

There was little if any attempt, by either the installer or the Government to educate the

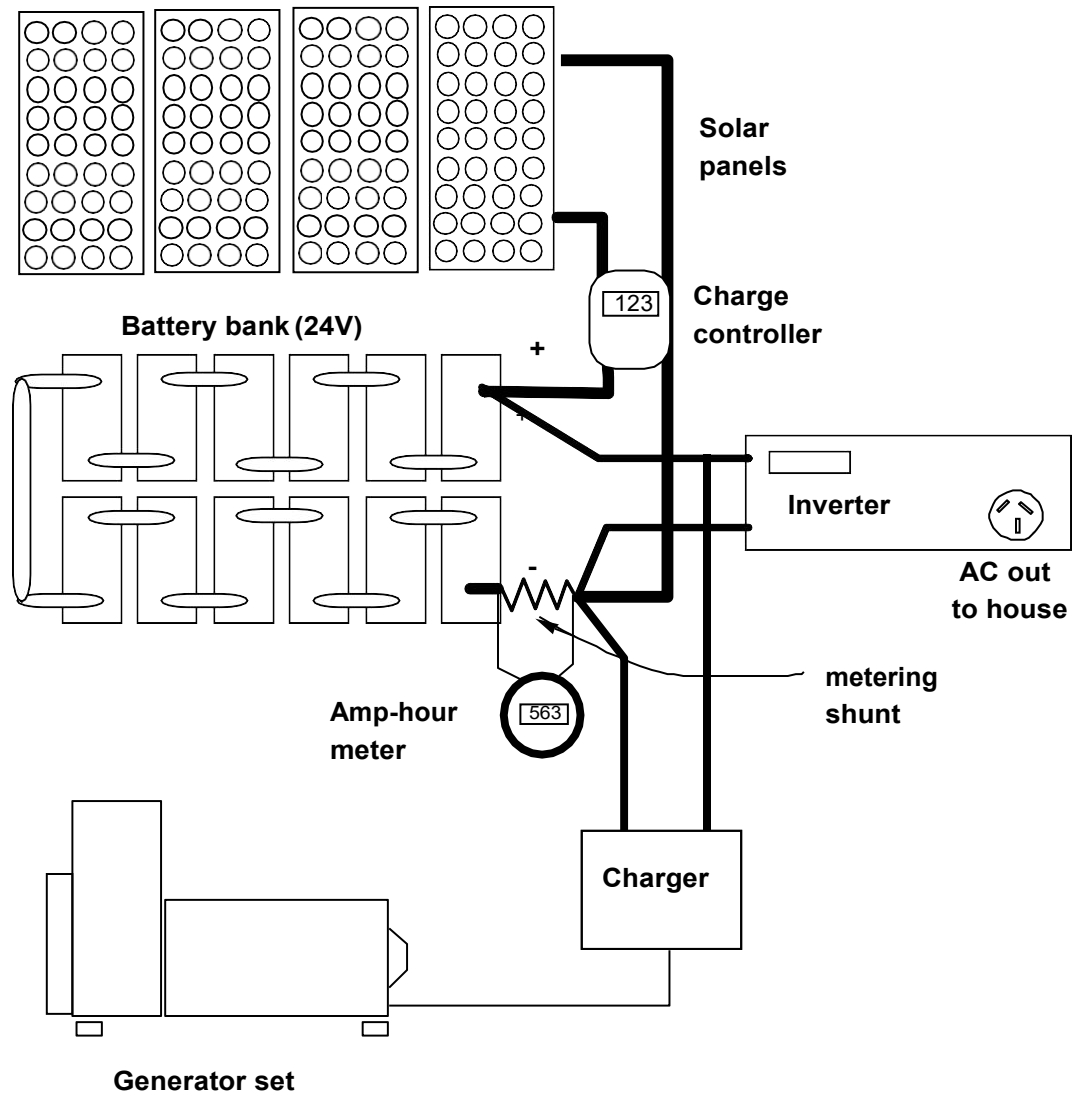
user (Daintree Power Surveys, Spencer et al 1994, 1998, 2000) which is reflected in the results obtained in this study.

(The DRAPS scheme was cancelled during the Borbidge National –Liberal Party incumbency (1996-99) for ideological reasons, but since contracts had already been entered into prior to their election, these installations were completed).

Basic system components were a 10 (80 watt) panel PV array (with a basic non- adjustable roof mount), a charge controller, usually specified by the PV panel supplier, batteries – almost all of which were approximately 1000 AH flooded lead acid types from three Australian manufacturers, a sinusoidal inverter, and, if the inverter was not a bi-directional inverter-charger, a basic battery charger. To top the list off, a petrol or diesel alternator (frequently 5KVA capacity ) to provide back-up and charging capabilities.

With further additions to the Daintree RAPS scheme following the re-election of the Beattie Labor Government, many residents upgraded their systems, largely through additions to the PV arrays. This uptake of the D-RAPS scheme was further encouraged by the ruling in November 2001, that further provision of grid based electricity north of the Daintree was prohibited by the Queensland legislature.

## Basic Solar RAPS system configuration.



**Figure 4 Basic layout of a conventional Photovoltaic Remote Area Power System (RAPS).** The solar panels would be normally be mounted as an array, usually on the roof of the building, with the batteries, inverter and charger either within the house or in a purpose built shed. The only unconventional aspect to the design shown here is the Amp Hour meter, which is missing from most systems, and is the subject of some discussion in the text. The generator is usually situated some distance from the house to reduce sound and fumes. You will note that ALL current to and from the battery bank passes through the metering shunt (a very low value resistor, which allows the user to monitor the current entering and leaving the battery bank).

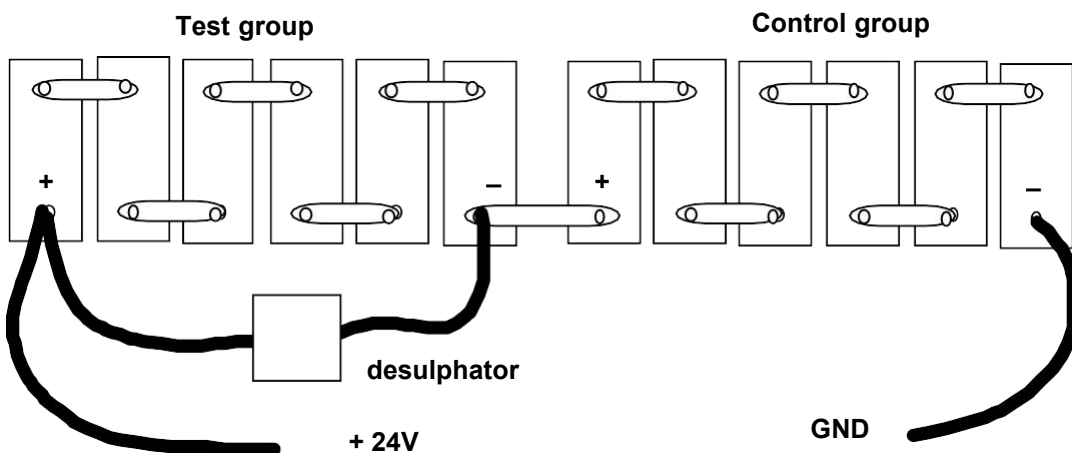
## Trial design

**Premature battery failure** has been observed as the most frequent issue degrading the performance of RAPS systems in the Daintree lowlands.

The initial aim of the project was to establish whether or not pulse de-sulphators afforded any protection to RAPS battery banks, or enhanced the operation of the system in the absence of other measures.

It was not considered realistic to run such a trial with the expectation that the householders would be prepared to follow detailed battery management instructions. Thus we decided to design the trial so that the battery bank (string) could be divided into two parts – one to act as the test battery, the other to act as the control. The Test group of cells were fitted with the de-sulphator, the control group of cells were not altered in any way.

In this arrangement all cells in the battery bank (which are connected in series to comprise what is termed a “string”) are subjected to exactly the same charging and discharge conditions, and so, any impact that a de-sulphator might be expected to have would be demonstrated as a statistically significant difference in capacity between the treatment and control sections of the battery. This approach compensates for all aspects of battery treatment and mistreatment by the householder.



**Fig 5 Test arrangement for the trial.** For 24 V systems both sides are identical with the battery string being divided into two equal parts.. For 48V systems, the control component would consist of the balance of the battery bank, equating to 18 cells.

With this experimental design we were obliged to restrict the trial to households using 24 volt or 48 volt systems, as the de-sulphators, while capable of operating at 12V would not operate below 8V.

As an inducement to house-holders to participate in the program, they were offered the fitting of the de-sulphator to the entire battery bank at the end of the trial, if it proved to be effective. This required that the de-sulphator be capable of operating at 12V and 24V without modification.

Critical to the success of the study was the ability to monitor the changes in the capacity of the battery banks as a result of the application of the de-sulphator.

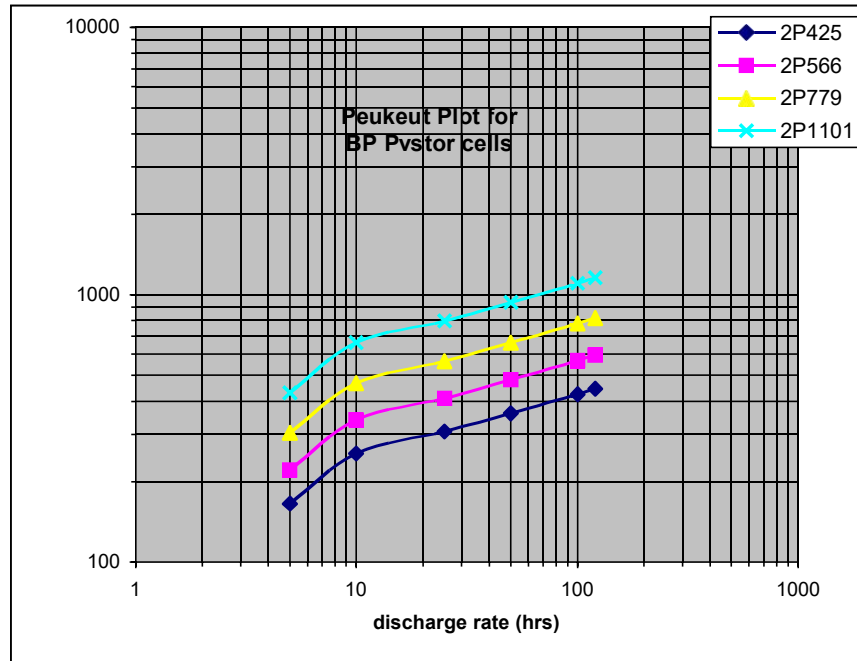
#### Battery capacity.

Capacity, which is defined as the current which the battery (or cell) can supply for a specified time (until the output voltage per cell falls below a specified level), is measured in Amp-Hours. Thus a battery capable of delivering 10 Amps for 100 hours, would have a capacity of 1000 Amp Hours (AH). This measurement of capacity does not take into account the voltage of the battery, and it is in fact a measure of the capacity of the cells that make up the battery. Capacity is conventionally measured by discharge tests. Discharge tests are extremely slow to carry out (and the battery must be immediately re-charged after the test is finished), and only give an indication of capacity at the discharge *rate* used for the test. They are certainly not appropriate for use in a study such as this one. Battery capacity is specified at a particular discharge rate, expressed as the time in hours over which the battery discharges 100% of the available energy (as defined by the drop in terminal voltage). So batteries can be rated at C10 (10 hours to discharge the full capacity) to C100 (100 hours to discharge).

Unfortunately due to the chemistry and construction of lead-acid cells, these capacities are not the same, and the higher the rates of discharge, the lower the available capacity, and hence the less power available to the householder.



This relationship between discharge current and capacity is called the Peukert relationship. (Fig 6 ).



**Figure 6 Peukert plot of change in cell capacity** (in ampere-hours) (Y-axis) vs discharge rate (total rated capacity discharged over a designated time) for the 4 cell sizes in the BP Solar PVstor family of flooded cell batteries. Batteries are sold on the basis of ampere hour ratings at the 100 hour rate (C 100). For a RAPS system using 1100 AH cells ( a common configuration in the Daintree), this would mean an average current draw of 11A or an average power draw of 132 watts (for a 12V system) to achieve this kind of battery capacity. For much of the operation of a RAPS system, the power draw will be well in excess of that and far less real battery capacity can be realised. (Data from BP Solar). As the discharge rate increases - 10 hour rate – (C10), and 5 hour rate (C5), the loss of battery capacity becomes very evident.

### Measuring Battery Capacity

Since a rapid and accurate measurement of capacity is essential for the assessment of the efficacy of the de-sulphator, we required an alternative testing method, and have chosen to use a relatively new technique, **conductance analysis**.

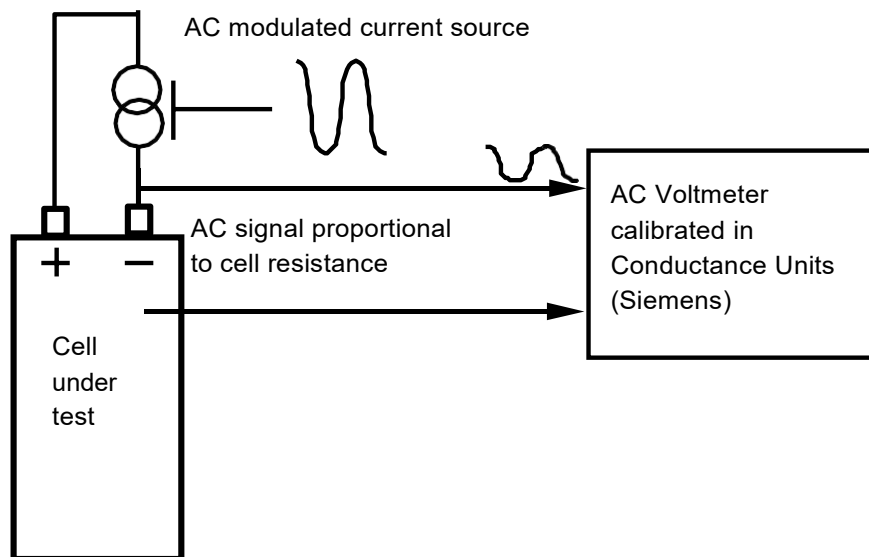
Conductance of lead-acid cells is inversely related to cell resistance, and is directly proportional to the amount of active area in the cell. A new cell has the largest possible active area (for the specific cell design) For a new cell the available electrical capacity is a direct function of the state of charge of

that cell, and this can be measured by discharge tests, measuring the specific gravity of the battery and

measuring the open circuit terminal voltage of the cell. However, as the cell ages and sulphation occurs, the amount of active material decreases, and these relationships between state of charge and capacity no longer hold. In a severely damaged cell – there can as little as 10% of the original capacity, even though the battery is “fully charged” as measured by specific gravity and cell voltage.

Conductance is directly related to capacity, as it reflects the active surface area of the cell. Thus we can expect that any appropriate measurement of conductance can be used to assess any changes resulting from the effect of the de-sulphator or other battery treatments.

#### Basic AC Conductance measurement setup



**Fig 7 Simplified arrangement** for measuring AC conductance of a cell or battery.

A constant current which is modulated by a (usually) sinusoidal signal, is caused to flow between the terminals of the cell (usually about 1 amp). As the cell has internal resistance (which derives from the resistance of the lead plates and the active material), this current will generate a voltage across the terminals that is directly proportional to this resistance and the instantaneous value of the applied current. As the current signal is sinusoidal and relatively small, aspects of the cell's chemistry that might produce non-linear effects do not impact the readings, and extraneous electrical noise (such as that from inverters and loads) can be filtered out by the AC voltmeter.

Conductance can be measured by AC impedance analysis, whereby an AC constant - current signal is impressed across the cell terminals and the AC voltage generated across

the cell by this current is measured and displayed as conductance readings; a relatively new technology (Fig 7).

The measuring frequency is often low, in the tens of hertz, and the voltage developed across the cell terminals is proportional to the resistance of the cell. The advantage of AC current analysis is that it is not polarity dependent, does not significantly discharge the cell or battery under test, and it can be carried out in about 30 seconds per reading.

**Conductance (C)** is the reciprocal of **resistance (R)** and is normally expressed in units (mhos or Siemens) which can then be expressed as whole numbers:

$$\text{Conductance (C)} = \frac{1}{R} \text{ Siemens}$$

Thus:

$$1 \text{ ohm} = 1 \text{ Siemen,}$$

$$1/100^{\text{th}} \text{ ohm} = 100 \text{ Siemens}$$

$$1/1000^{\text{th}} \text{ ohm (1 milliohm or 0.001 ohm)} = 1000 \text{ Siemens}$$

The larger the active surface area of the cell, the lower the cell resistance, and the high conductance readings better reflect this. A large flooded 1000 AH cell typically has a conductance of about 3000 Siemens (1/3,300 ohm or 0.00033 ohms). Conductance is usually measured on a cell by cell basis. Total battery string conductance (the conductance of all the cells in series) it is far less informative than measuring the conductance of the individual cells, as the all important variation between cells that can indicate potential problems, will be overlooked. As the cells of a battery are in series, the total conductance will be the reciprocal of the total cell resistance (unlike resistance, conductances in series do NOT sum).

$$\frac{1}{C \text{ battery}} = \frac{1}{(C_1 + C_2 + C_3 \dots + C_n)} \text{ where } C_1, 2, \dots, n \text{ are}$$

the conductances of each of the cells

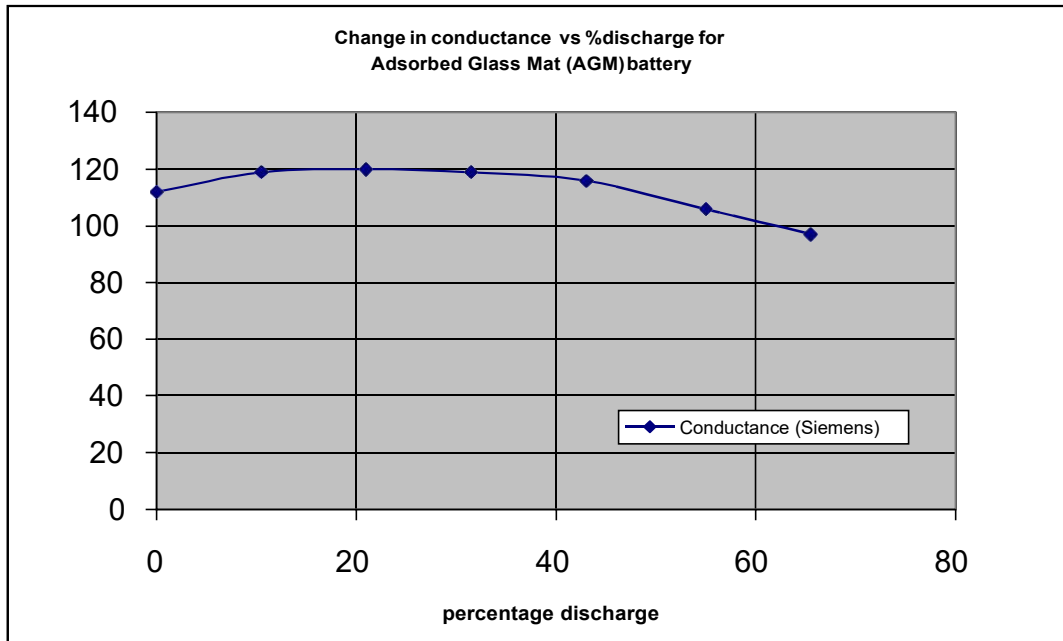
A US firm Midtronics manufactures a micro-computer based digital conductance analyser, the “Micro-Celtron” CTM 100, (Fig 8) which we have obtained as part of

the project, which permits measuring battery capacity in a very rapid and reproducible fashion without requiring interruption to the RAPS system operation.



**Figure 8 Celltron CTM-100 Conductance analyser.** This battery powered instrument does not require significant current from the cell under test, and may be used while the battery bank is in service. The two battery test probes can be seen to have 2 spring loaded pins which dig into the lead terminal posts. This is called a Kelvin connection, and allows the instrument to measure currents and voltages at the point of connection with the battery posts, rather than have the signals affected by voltage drops in the instrument cables. This greatly increases the accuracy of the instrument. The Celltron has an internal logger which allows storage of readings for later print-out.

### Relationship between conductance and state of charge



**Fig 9 Change in conductance** (in Siemens, vertical axis) as a function of the discharged state of the battery - in this case an old 12V Hawker AGM battery with a nominal starting conductance of 120 Siemens (26AH). It is evident that the conductance only significantly reduces when the battery discharge level reaches about 60%. As a result, the conductance readings give a fairly good approximation as to battery “State of Health” – at least for relatively well charged cells.

We have been unable to determine whether this relationship holds for a conventional flooded lead-acid cell, primarily due to the difficulties in re-charging large 2V cells at high current. However it is a reasonable supposition to make that it does in fact hold.

### The De-sulphator

The de-sulphator is an extremely simple electronic device which is designed to inject a high current pulse into the cell, a pulse that has a very fast rise time and short duration, the fast rise time is deemed essential to “twang” the electrochemical process. Many designs for de-sulphators exist, at least 20 patents are registered in USA alone, There appear to be two main types – a ringing pulse (“modulated pulse”) and a simple pulse variety – that generates a single monophasic pulse at a high repetition rate. The advantages of one over the other are unclear, but as the simple pulse generator is electrically the simplest to implement it was used for the trials.



Because of the high cell capacitance (large physical size and plate area of the storage cells) – it was considered that the highest pulse current available should be used

(= lowest pulse source impedance) , so that the cell capacitance would not degrade the rise time of the pulse . Published designs had currents in the order of 10 to 50 A, but it was felt that the highest currents available should be used. Pulse widths of 50 - 100 nS seemed to be optimal, with repetition rates of about 1000 per second. The basic design was published by Alistair Couper (2000) – but analysis of the circuit indicated that as published it was incapable of generating significant current – but that the basic circuit could be used without significant modification. An analysis of the function of the pulse forming components, suggested modifications, which initially resulted in pulse amplitudes of 500+ amperes with the appropriate pulse width and duty cycle – further assessment of other components, yielded a device that could reliably deliver 1000+ amp pulses into a 12V battery that was used as the test system. (for details of the design and testing, see Appendix 1)



**Fig 10** Packaged de-sulphator, ready for installation. Caliper is 230 mm long. Note heavy high current wires.

50 of these high-current de-sulphators were constructed at the Research Station for the project (there being no equivalent commercial unit available).

Eight prototype (Hotwire, Adelaide) commercial modulated-pulse de-sulphators were employed towards the end of the trial, as they were not available earlier.

#### De-sulphator Battery Connections

To reduce pulse amplitude and shape losses the project de-sulphators were provided with connections of 6mm diameter (conductor) flexible high-current cable fitted with sweated tab connectors. Total connection length was 1 meter, adequate to reach across a set of 6 Suncycle 1100 AH cells.

The commercial de-sulphators (Hotwire, Adelaide) were supplied with 2 meter leads (2mm conductor diam), and the pulse amplitude losses with these wires appeared to be significant, about 33%.

#### Package

The high current de-sulphators were packaged in a 5x4x3 cm encapsulation box and filled with commercial urethane encapsulant. The commercial units were already supplied encapsulated.

### **Installation**

The de-sulphators were installed as they became available, starting in September 2001. During installation, the conductivity of all cells in each battery bank was recorded, as this became the “initial” condition of the system and the nature of the devices that made up the RAPS installation were also documented. Many householders also used the opportunity presented by the presence of the surveyor to ask questions about their system and about RAPS systems in general. In fact this proved to be a very valuable aspect of the exercise. A digital picture was taken of each installation when it was completed.

## The Survey

### Trial population

Letters were sent out to those householders identified by the Queensland Department of the Environment as having RAPS systems, on behalf of the project. Those responding were contacted by the Project and their systems assessed for suitability. Because of the low voltage limitations of the de-sulphators, householders with 12 volt systems were excluded from the study. This significantly limited the number of households available, and while it was hoped to recruit 75 householders, only 53 households completed the study period, including 5 households with 48V systems.

As part of the incentive to join the survey, householders were offered the opportunity to have the de-sulphator as a gift, assuming that it in fact proved effective. As a result, integral to the de-sulphator design, was the requirement that it operate equally effectively on 24V as on 12 V, a requirement that was easily met.

### Other involvement

Invitations were sent to installers involved in the original D-RAPS installation program, and of these only 2 responded, the major installers evinced total disinterest in the project.

Similarly letters of invitation were sent to the 3 main battery manufacturers, and no interest was evinced either.

### Assessment procedure.

Originally it was proposed to assess the state of battery cell conductance on a monthly basis, but it became obvious that this was excessive and a 6 month interval would be adequate. Besides, frequent assessment visits were felt to be intrusive to many home owners.

At each assessment visit the cell conductance was measured and recorded, and where possible, the householder was interviewed informally about their

experiences with their systems since the last visit.

## RESULTS

Fifty three households completed the study period, some dropping out because of major changes in their system due, largely to battery problems that were well advanced when the study commenced, or where the householder had interfered with the battery bank (swapping cells, for example).

Effectiveness of monophasic high current de-sulphator design on the capacity of flooded lead acid cells.

De-sulphator effectiveness was calculated as:

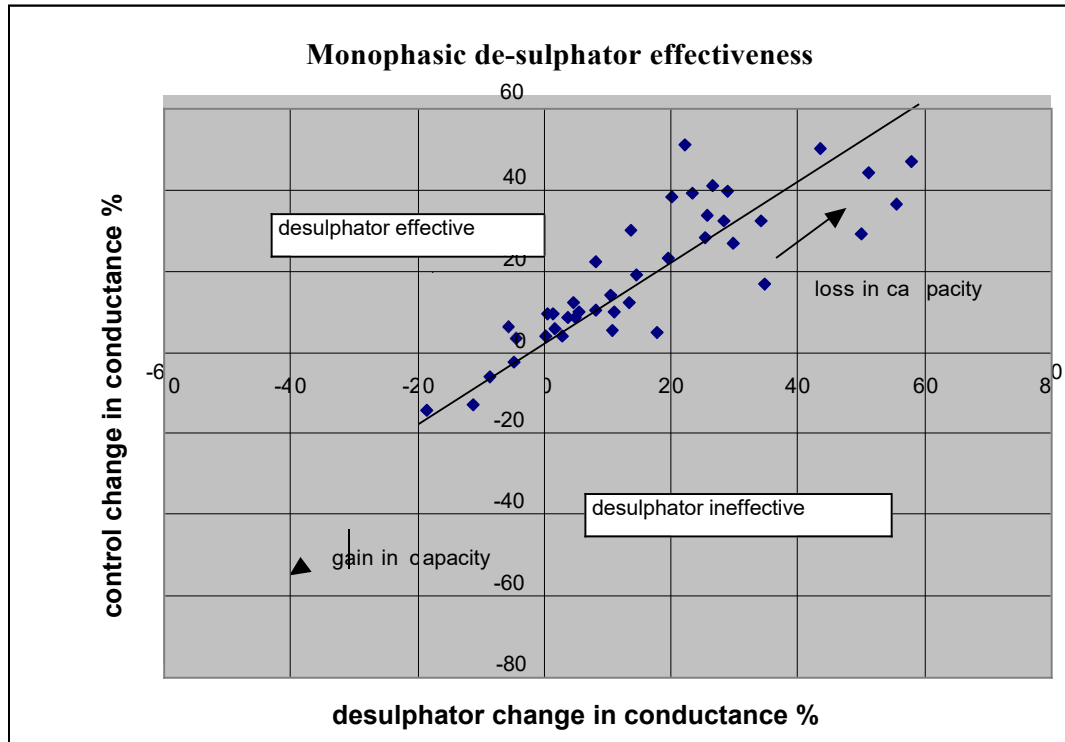
$$\frac{\text{Initial average conductance} - \text{final average conductance}}{\text{Initial average conductance}} \times 100$$

Calculated separately  
for both groups of  
cells (control and  
de-sulphator)

Division of the averaged difference in conductance by the initial average conductance provides a normalising function (expressed as a percentage) allowing us to compare the effects of the de-sulphator on cells of different amp hour capacities.

An increase in battery capacity (as indicated by an increase in conductance) will thus be manifested as a negative value for the formula above, the larger the value (a shift to the lower left, in Fig 13 below), the greater the improvement in battery performance. A decrease in battery capacity, will produce a positive shift (to the right of the trend line). No change in capacity will produce values clustering around zero. No alteration of battery degradation by the de-sulphator treatment (whether or not the batteries degraded or improved as a result of other effects), will result in points lying along the 45 degree trendline. Improvements in battery maintenance and attention to charging during the course of the study are manifested as shifts along the trendline, with improvements shifting points along it to the left and degradation causing shifts along it to the right.

Figure 13 shows that installing the high current de-sulphator does not appear to have made dramatic improvements in cell performance, but there is certainly a beneficial effect for the majority of batteries.



**Fig 11 Plot of conductance changes in the test battery population** resulting from the application of the monophasic pulse de-sulphator.

Where the axes cross is the zero point of the graph, and values clustered around these points indicate that there has been no significant change in capacity in the battery bank, over the duration of the test. The 45 degree trend line indicates line where both the test and the control sections of the battery have deteriorated equally (right of zero) or improved (left of zero), and there is no discernable effect of the de-sulphator.

Points to the left of the trend line shows that the de sulphator has increased the capacity of the test section compared to the control (has been effective), despite general reduction or improvement in capacity of the entire battery. Indeed it is possible that some points on the RHS suggest that the de-sulphator had a negative effect on a few batteries (though the mechanism for such a negative effect is unknown).

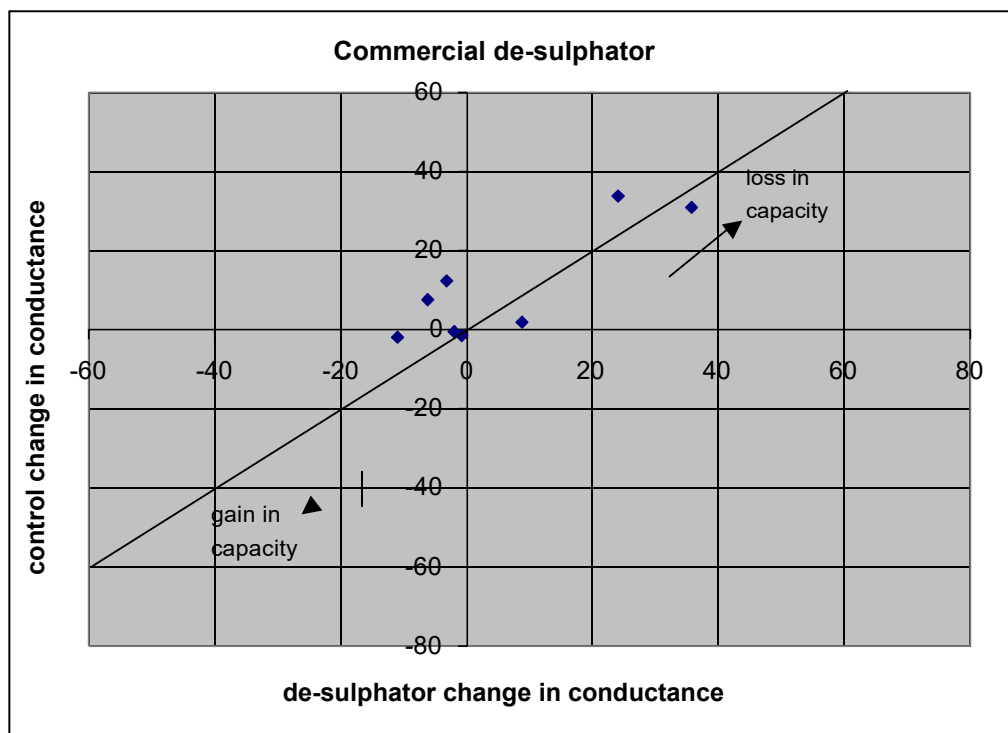
The figures are in percentage loss (or gain) in capacity, referred to the initial set of conductance measurements made at the beginning of the study, with the % change in the test cells on the X axis, and the change in the control cells on the Y axis.

**The clustering of points to the left of the line indicates that although virtually all systems have degraded during the course of the study (with only 5 showing improvement over**

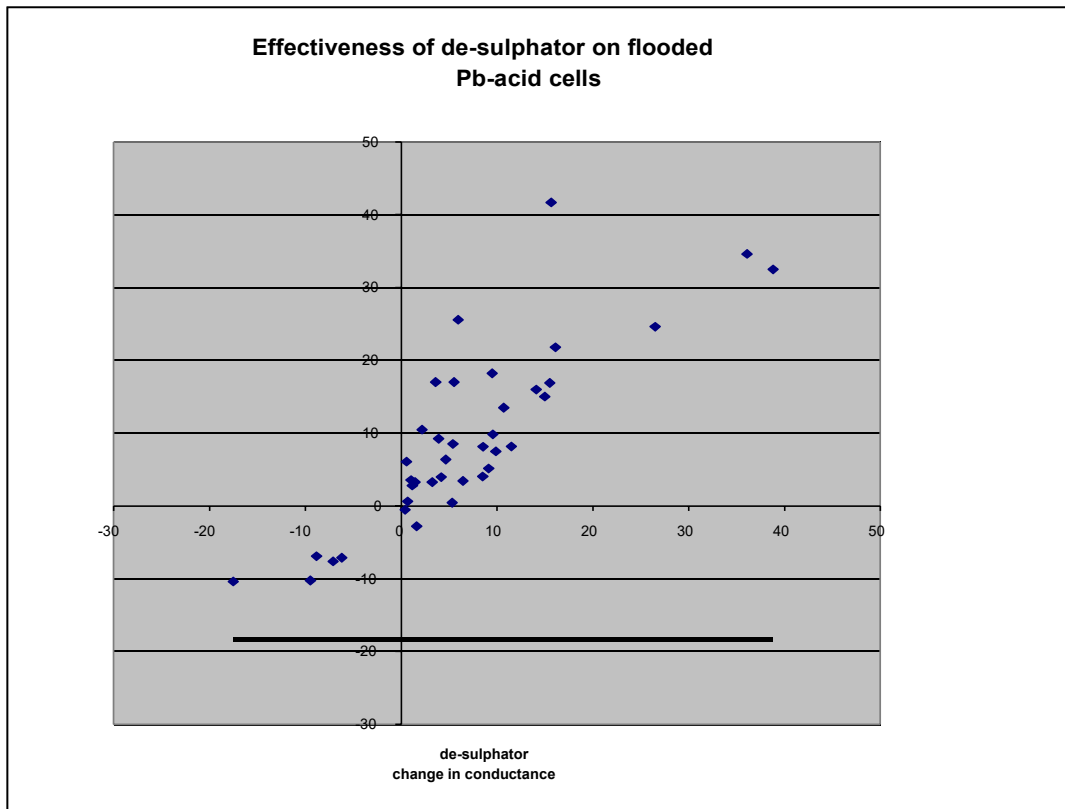
the original state), 23 systems have shown a reduction in degradation which could be ascribed to the action of the de-sulphator.

One system demonstrates a quite spectacular improvement, which doesn't appear to be due to the de-sulphator. The battery of this system was in very bad shape at the start of the trial and improved, presumably due to a greatly increased frequency of equalisation charging (that is, the system owner started to take notice of his system, as we were using it as an experimental subject!).

Points in the far upper right hand of the graph, to the right of the trend line, are harder to interpret – either the desulphator has had a negative effect (unlikely), more likely that the degree of conductance variation of batteries showing this degree of damage (30 to 60% loss of conductivity) is such as to make any interpretation of the results (favouring or otherwise the effect of the de-sulphator) moot for this group. The behaviour of such cells can also be unpredictable.



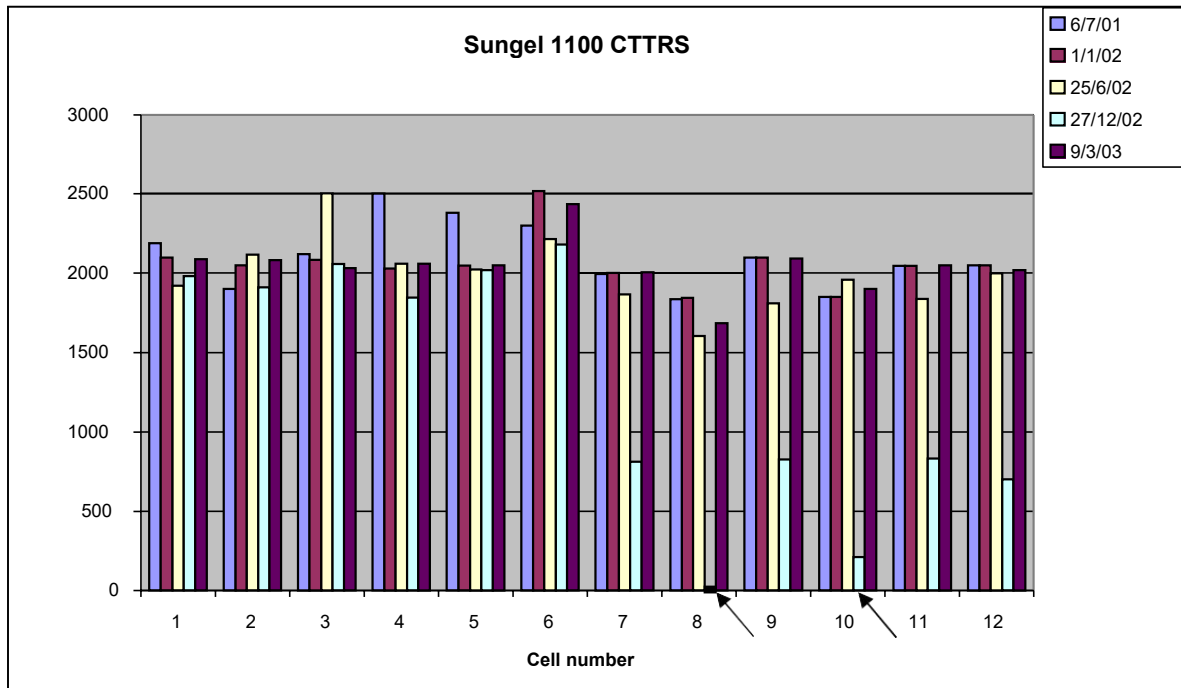
**Fig 12 Plot of conductance changes in the test battery population** resulting from the application of the commercial sweeping pulse de-sulphator. Unfortunately only 8 could be installed, so the performance of this population and the preceding population could not be statistically compared. However, the pattern is much the same suggesting that it was also somewhat effective.



**Fig 13.** This was the original plot from the preliminary report, with data that ended in February 03. Between these measurements and the final measurements in September 03 the Daintree lowlands experienced a prolonged period of very cloudy weather, and many of the systems collapsed. Comparing this graph with that of Fig 10, shows the additional number of points that have shifted very significantly to the upper right of the plot as a result of battery cell failures (those systems whose capacity has fallen in excess of +20% have risen from 6 to 17). The distribution of points to the left of the trend line has changed as well.



## A particular case – Gel Cells.



**Fig 14. A time series indicating the dramatic effect of the de-sulphator** fitted to the only set of GEL cells in the study, those installed at the CTRS power system, Sungel SG1100 (Battery Energy), originally installed in June 2000, replacing the original BP 1100 cells. The de-sulphator was fitted to cells 1-6 on 1 January 02, with cells 7-12 as the control section. Approximately 6 mo later, the conductance of the cells on the test side remained constant or had improved, those on the control side had started to show a decline in conductivity. On the 27 December 02, after a prolonged period of cloudy weather, the system failed, with the conductivity of two cells (**8 and 10**) falling to lows of 22 and 209 Siemens (**arrows**) (nominal original value 2000), indicating very severe damage, while the others fell to an average of 700. A second de-sulphator was immediately fitted across cells 7 – 12, and the batteries were brought up to equalisation voltage using the generator and maintained in this state as far as practicable. Conductivity readings on the 9 March 03, indicated that the cells had made good recovery, but cells 8 and 10 had not achieved their pre-collapse conductance levels (and were subsequently replaced). Cells 7 and 9 collapsed in Nov 03. and were replaced. **Cells 1-6 have retained their original conductivities.**

**While not in anyway conclusive, this observation strongly suggests that the de-sulphator exerts a very significant protective function on GEL Pb-Acid cells, quite distinct from its impact on flooded Pb – Acid cells. Unfortunately this is only one example, as the Research Station was the only system in the study using such battery technology.**

Interestingly the end-of-study values for the effectiveness of the conductance change (see Fig 10 ) for this installation, was Test 0.66%, and Control 1.21%, showing a slight improvement in average conductance figures of the test side.

It has been suggested that the de-sulphator may, by maintaining a high conductance on one half of the battery bank, unbalance the battery string, and cause the collapse of

the unprotected side. Reflection would indicate that in fact the reverse would be true, as the charging requirement ( in AH) of the higher capacity (protected) side would be greater than the unprotected side, and to achieve float voltage (fully charged voltage), the unprotected cells would be forced to continue gassing, which should ensure their achieving full charge as well.

The observed effect of the de-sulphator, supports informal observations made by other investigators and that of the authors (that they can be remarkably effective in rehabilitating small gel cells) , that de-sulphators showed most effect on gel cells, and least on flooded lead acid cells.

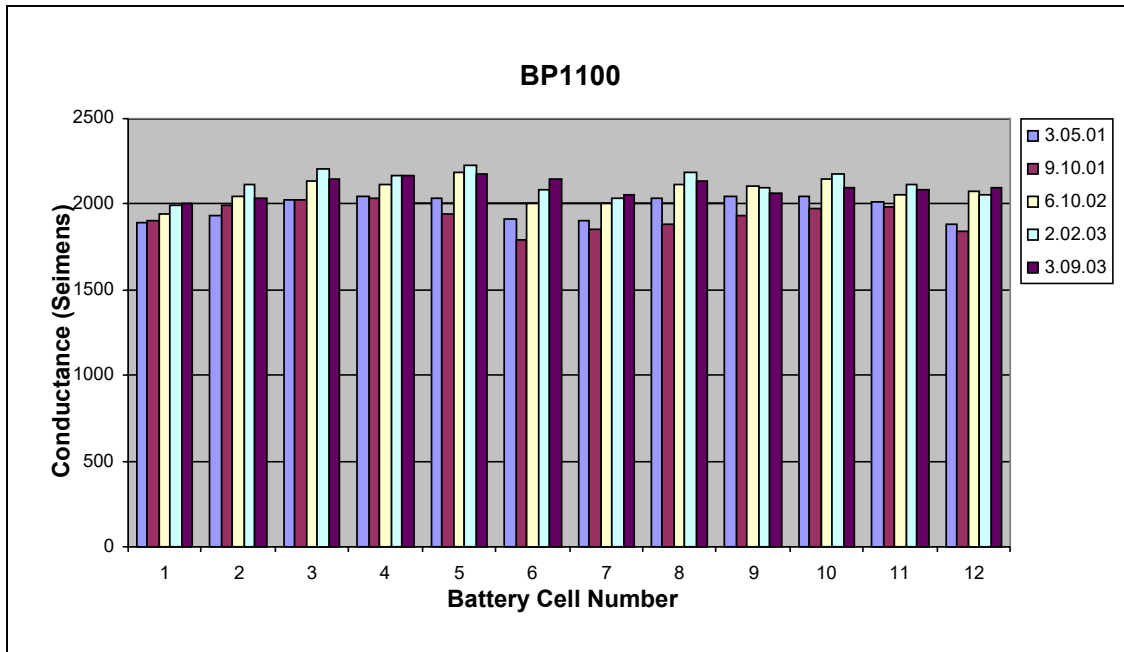
Unfortunately the sample of the commercial (HotWire) de-sulphators was too small (and the number of available households too small) to make any statistically valid comparisons with the monophasic units, but it appears that they also have had some positive effect on battery capacity as well.

As is often the case in studies such as this, even with an experimental design that compensates for the expected variation in battery behaviour during the study, the range of battery conditions actually encountered, made a detailed analysis of the impact of the de-sulphators very difficult indeed, even with the experimental design used. If further installations of gel cells or AGM cells are made in the area, it would be well worthwhile fitting the de-sulphators to these battery banks and monitoring their long-term effects.

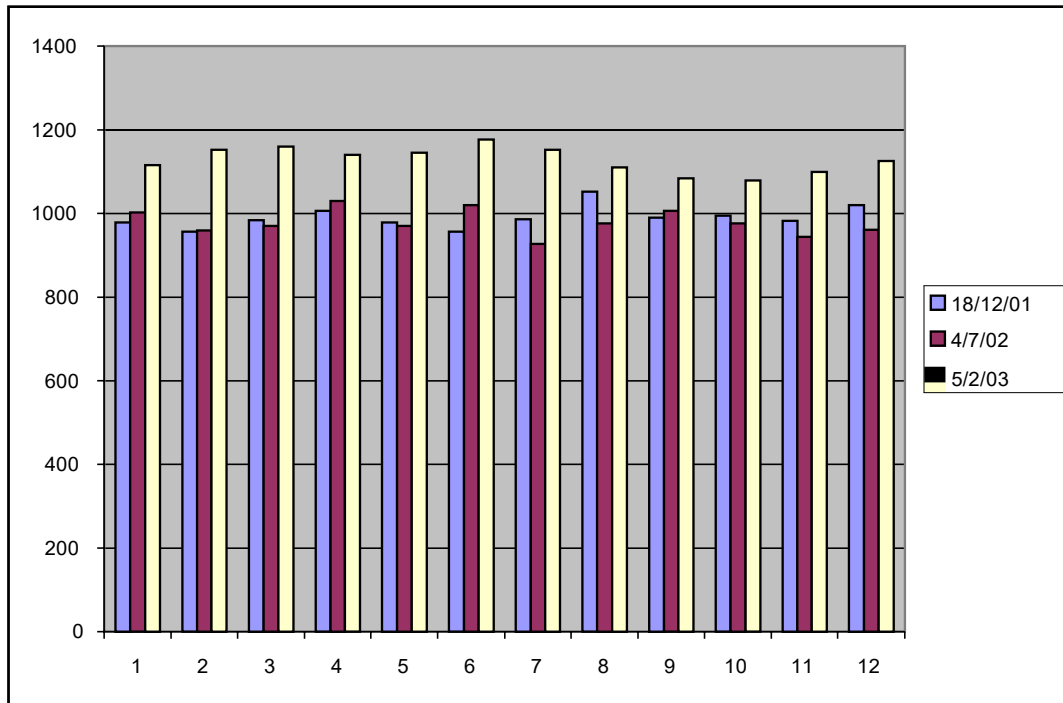
Some of the results also suggested that the de-sulphator exerted most of its effects early in the study, and its continued use caused some degree of degradation (at least for flooded cells). Unfortunately the variability in battery conditions encountered during the trial makes it very difficult to verify this. Certainly the gel cell bank have continued to show maintenance of capacity on the test side, a long-term positive effect.

Examples of battery behaviour encountered during the study.

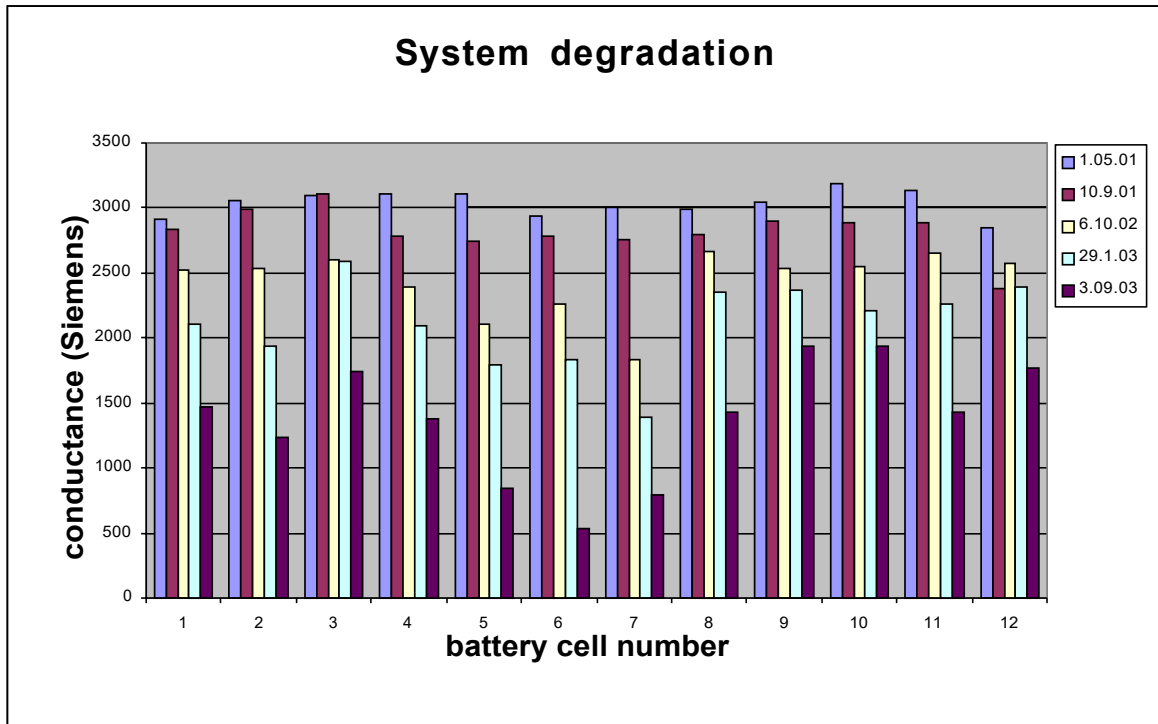
In all the following time-sequence plots, cells 1-6 are the test cells with the de-sulphator and 7-12 the control cells. The vertical axis is conductance in Siemens.



**Fig 15** An example of a well maintained battery of flooded Pb-Acid cells, BP PVStor 1100) (which were aging – as the conductance is approximately 2/3rds the conductance of new BP 1100). However, the de-sulphator appears to have had little effect as the substantial improvements in this bank have been due to the owner assiduously equalising his battery bank and monitoring his power useage. This system had 1350 watts peak solar, good insolation, and a fairly low use of power – resulting in cells that were maintained at high charge levels, and whose capacity has improved with time.



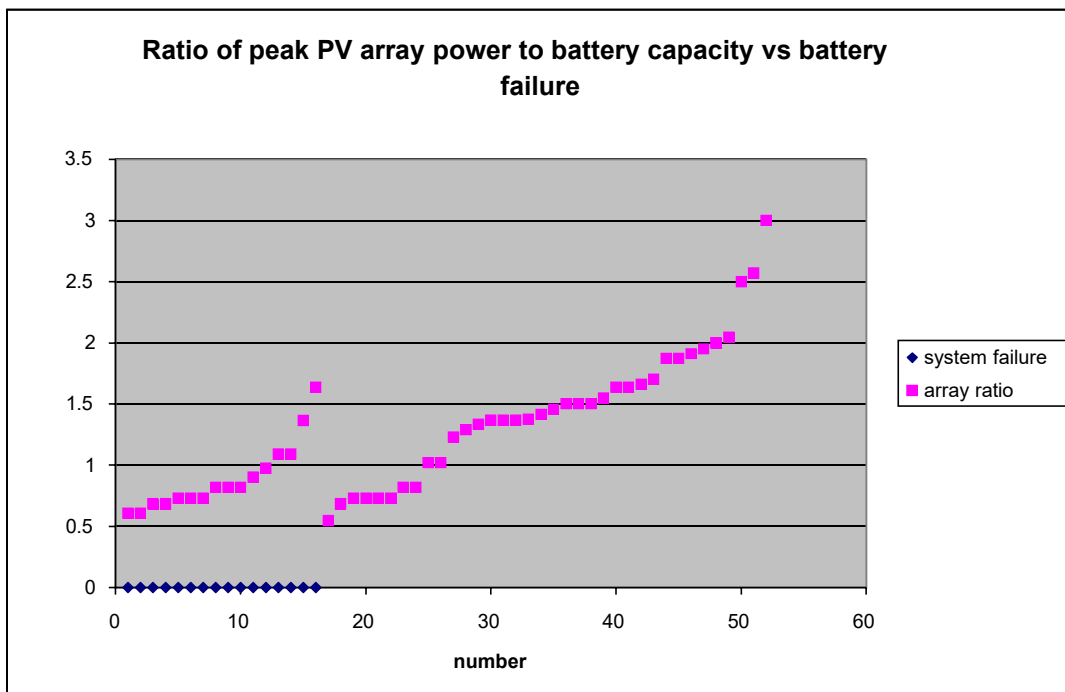
**Fig 16** A well maintained set of Century-Yuasa SSR700 tubular plate batteries. The evident improvement in the conductance of the cells at 5/02/03 is largely due to improved charging and equalisation by the householder. However, the TEST group showed an improvement over the CONTROL (-17.5%, -10.38%), indicating that the de-sulphator was quite effective in this instance. This installation, although only having 900 peak watts of PV, had good insolation and low loads.



**Fig 17** A set of originally well maintained AS1100 batteries which have seriously degraded as a result of additional load (refrigerator – added August 02) and lack of metering (and hence lack of regular equalisation) There is a small early positive effect of the desulphator, with TEST values of 16.13 % and Control 21.8%, but it clearly was not able to prevent the loss of capacity of the TEST side. The site is also partly shaded, so insolation is restricted. Added to this, was the additional 5 month period of overcast weather in the first half of 2003, which caused total system collapse. This installation has 1500 watts of PV, but the refrigerator tipped the load profile, and in the absence of a satisfactory amp-hour meter, the generator was not run sufficiently to equalise the cells.

Unfortunately 27 of the 56 systems which took part in the study showed battery degradation similar to or worse than this example.

### Relationship between PV array power and battery capacity and battery failure.



**Fig 18 Ratio between the installed peak PV array power (in watts) to incidence of battery failure.**

Peak solar array power (watts) is divided by the installed battery capacity in AH to yield an numerical index (vertical axis) which provides a rough index of the adequacy of the solar power available (but of course does not take into account loads - which we were not able to measure). The first 16 points (blue) correspond to the ratio for those systems that failed (that is where one or more cells collapsed during the period of the trial). The remaining 36 points correspond to systems where there was no collapse or only a general degradation of capacity during the period of the trial.

All systems are 24V. Those systems with an index greater than 1 showed a greatly reduced incidence of failure. In its essentials, this indicates that the larger the solar array relative to the battery capacity, the more likely that the batteries will be adequately charged.

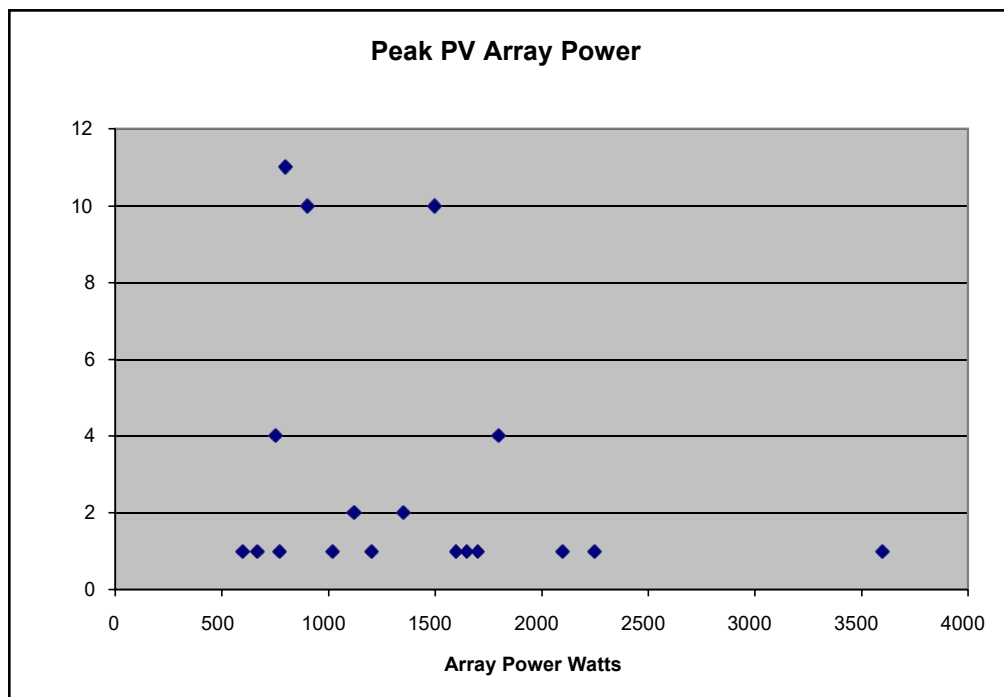
**This data was compiled from the results obtained in Feb 03, so does not take into account subsequent failures from the 5 month overcast period early 03, in which a further 11 systems failed.**

It is clearly evident that where there is adequate solar PV capacity (ratio of 1.25 and above), the probability of battery failure reduces very sharply.

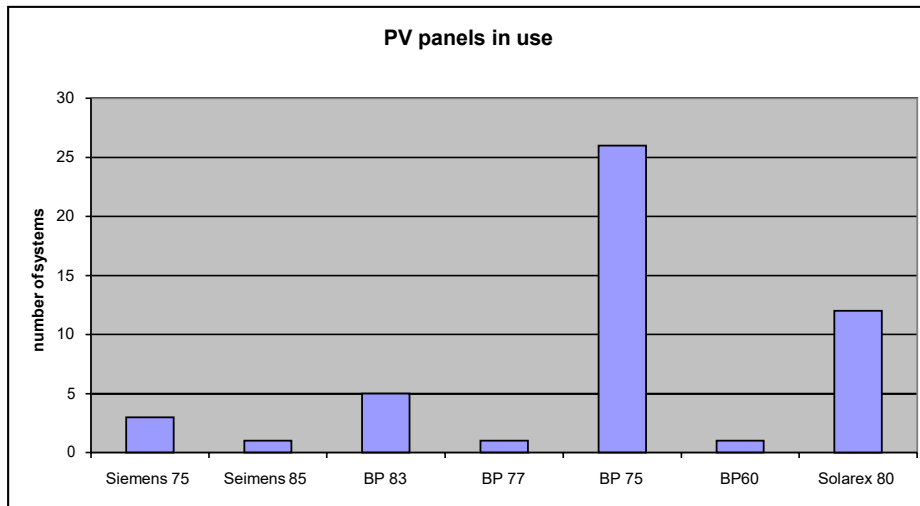
. It should be noted that virtually all arrays were mounted on roofs with a fixed array angle (15-30 degrees) which favoured solar insolation during the winter months (the

period of **best** solar conditions) – during the more problematic summer periods, the array output was substantially reduced (see Fig 28) at a time when periods of good insolation were at their minimum – contributing to lower battery charging at this critical time. The degree of orientation of the panels towards true north was rather variable, adding another factor that conspired to reduce solar efficiency.

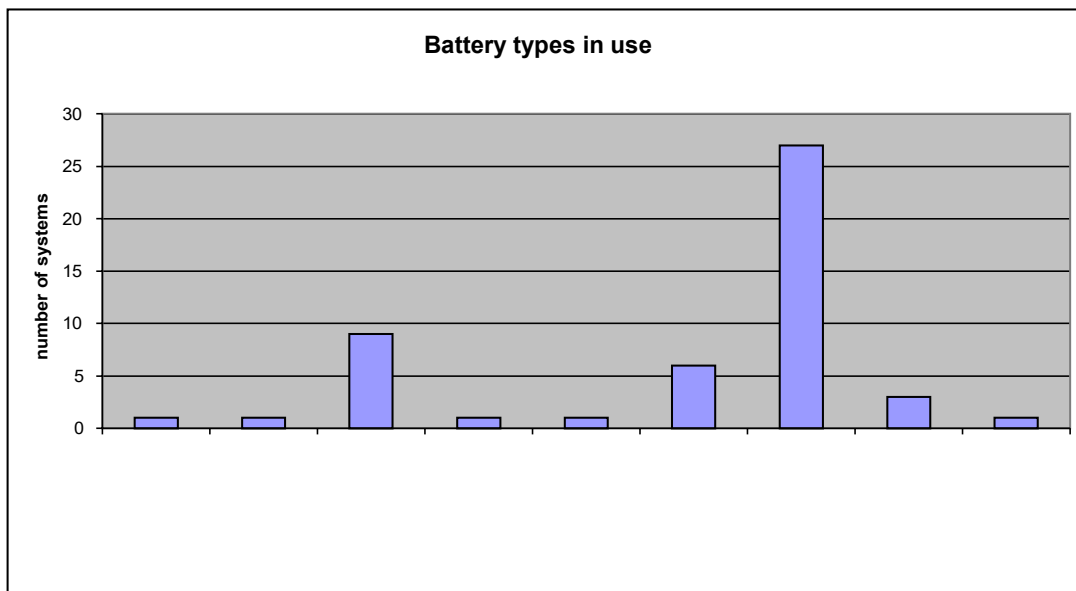
#### Details of systems encountered during the study.



**Fig 19** The distribution of installed peak power of arrays was dictated primarily by economics rather than by design, as determined by the funding available through the Daintree Renewable Power Supply (DRAPS) program. The basic array size (700 to 900 peak watt) was the commonest initial installation size, and residents accessing the second round of the RAPS funding scheme (about 30%), used it to double the number of panels, giving array sizes of about 1,600 watts peak. Vertical axis - numbers of households with this array size.

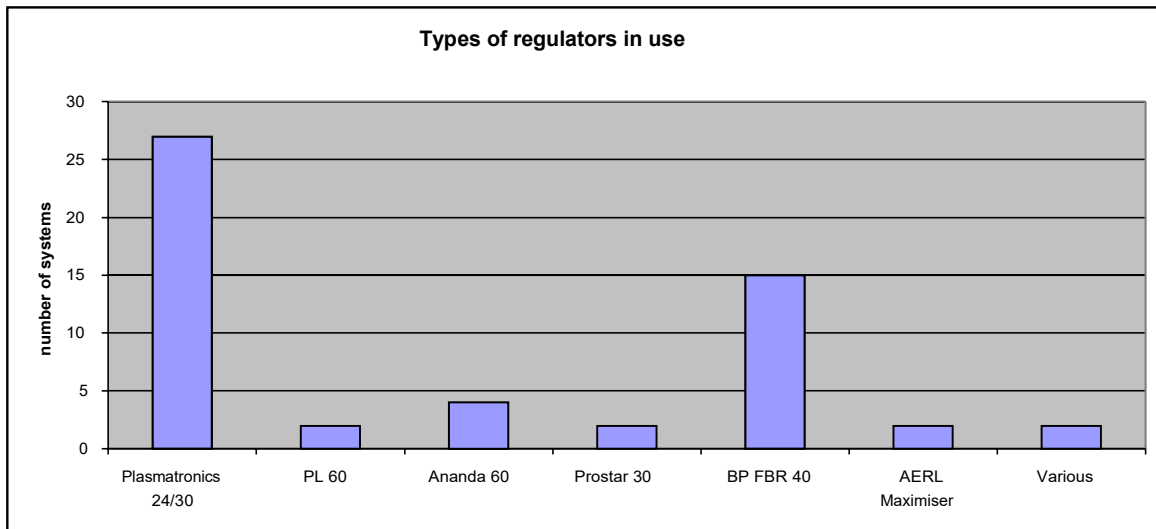


**Fig 20 Distribution of solar cell types** encountered in the survey, Monocrystalline cells (BP and Siemens) are the dominant variety (percentage) with poly-crystalline (Solarex) cells less favoured by the installers. This was driven by economics and installer discount structures rather than by any technical issues.

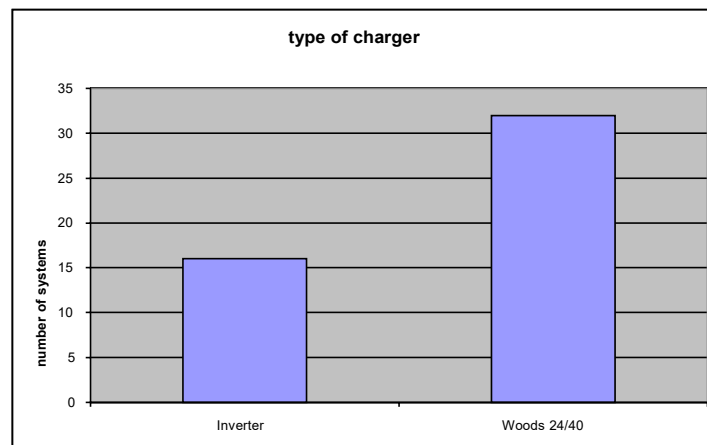


**Fig 21 Battery types encountered during the survey.** As is evident, the battery types installed are primarily flooded lead acid cells, with one example of a gel-cell system (SunGel 1100). The Century Yuasa SSR series batteries are lead-calcium tubular plate construction, the remainder are lead antimony construction. Most systems have battery capacities in excess of 600AH (C100 rate). 24V.

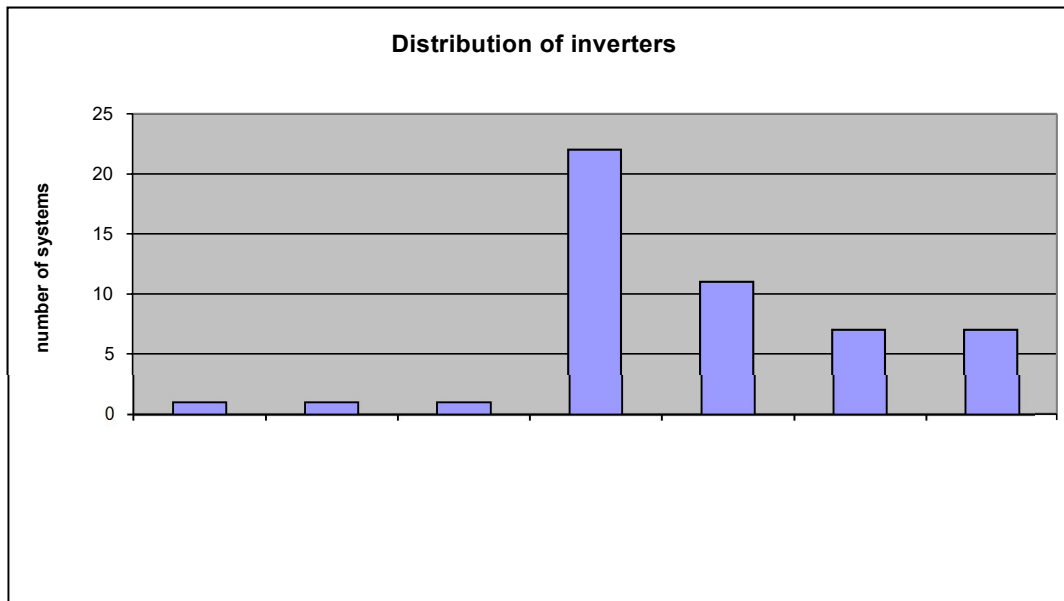




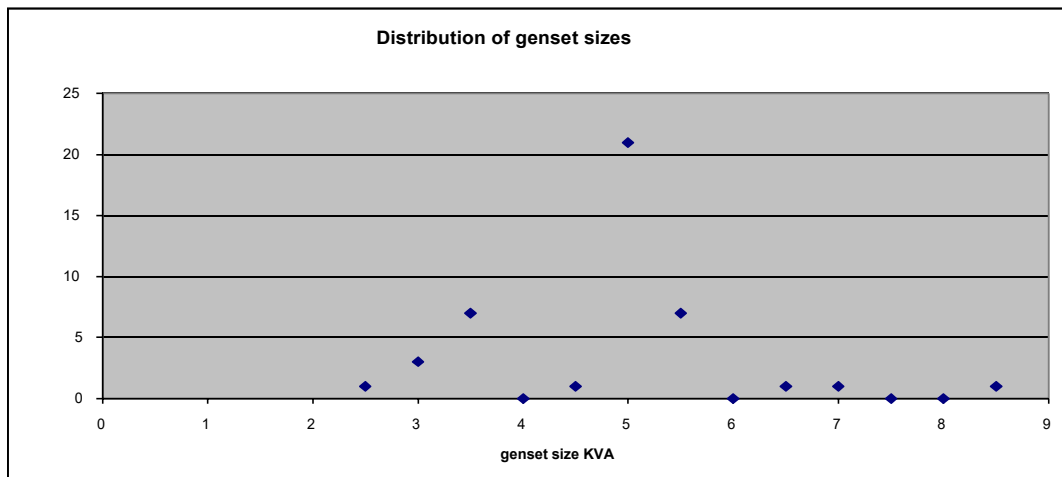
**Fig 22 Distribution of regulator types** encountered during the project. Regulator choice appears to be dictated by the preferences of the installers - the Plasmatronics PL 24 (a series PWM regulator) is a very basic regulator supplanted by the larger PL60 which has considerable data logging capabilities. The BP FBR 40 was frequently packaged with the BP panels, and also has fairly good data display. The AERL Maximiser which employs “peak power-point” tracking and functions as a charge controller, can increase the effective solar input from a given solar array up to 30% additional array power - under conditions where the conditions are not favourable - (low batteries, overcast, cold and winter conditions), and it has a basic data display.



**Fig 23 Distribution of charger types.** At the time of installation (c 1997) there was a very poor selection of battery chargers available to solar installers - within this sample there are only two options in use – the inverter/charger (which is the most efficient of the charger types) and the Woods charger, which is a conventional full wave linear battery charger with a primitive variable voltage capability. During the course of the survey several households purchased Stanbury stand alone battery chargers, which offer higher currents, and are basically a telco style charger. No household had a stand-alone switchmode charger.



**Fig 24 Distribution of Inverter types.** Two general inverter types are used – the stand alone inverter (Selectronics, Latronics) and the inverter chargers (Trace, Sunsine, CSA and SEA), which are more expensive, and combine the capabilities of inverter and charger into one package. All have some form of data display – which often depend on the options fitted by the installer.



**Fig 25 Distribution of Genset capacities.** 5KVA 3000 rpm manual start gasoline gensets are the cheapest, most readily available, and have been installed in the majority of systems. They are also extremely noisy and have short lifetimes. Unfortunately because of the limited capabilities of the battery chargers (1.2 kW at the most – due to design constraints that prevent “linear” chargers from utilising more than 40% of the genset capacity) the capacity of these gensets is rarely used, and result in substantial fuel inefficiencies (unless the householder uses the excess load to perform tasks requiring higher power (drying, vacuuming)).

## Issues:

### Cultural/Sociological issues

For a variety of historical reasons, there is no “community” as such in the region north of the Daintree River, rather there are disparate groups of people bound by employment, choice of recreation and interests. There is little interaction between the groups, and there are few “neutral” areas where people with disparate interests can mix. Attempts have been made to establish such venues (CILG, Diwan Community Centre, Alexandra Bay School, local action groups) but by and large for newcomers the isolation can be pretty daunting. As a result people do not know where to go for solutions to their RAPS problems, or may be dissuaded by gossip from seeking it. As a result settlers “go it alone”, often with disastrous results.

Unless there is a sale involved, most installers appear not interested in providing free information or rectification of problems which are in many cases well past any warranty period, and the Daintree is a very long way from Cairns where most of the installers are based.

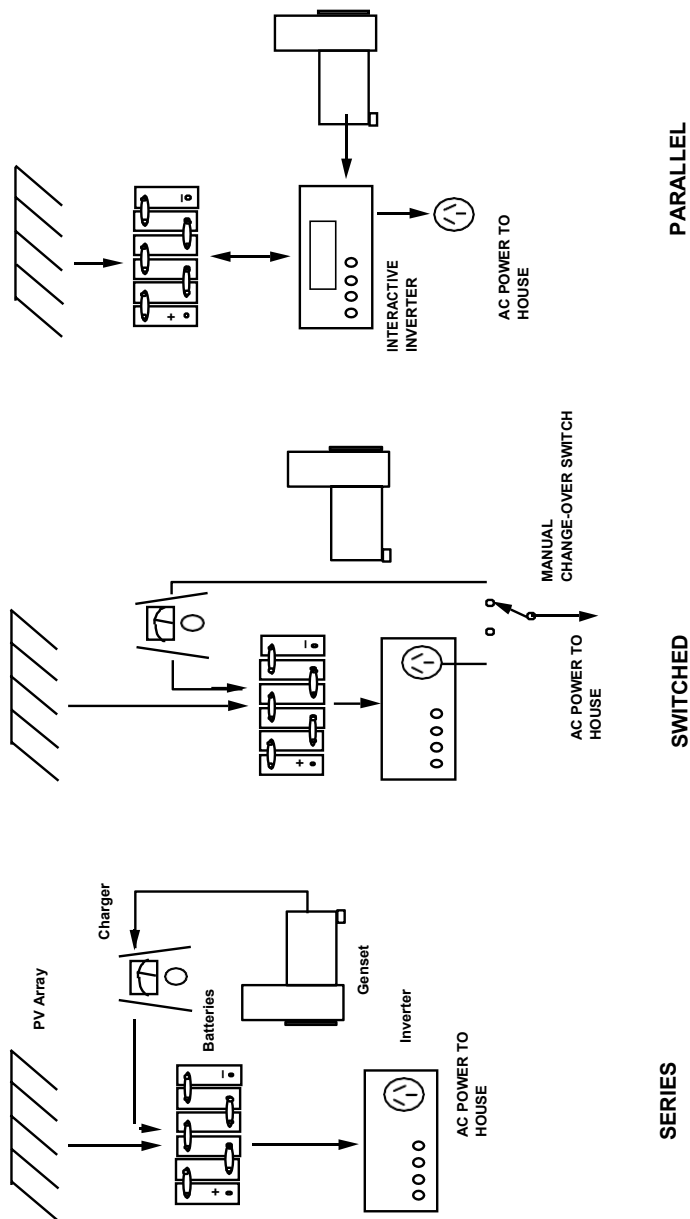
Expertise does exist in the area, but the people cannot be expected to provide assistance at no charge.

Added to that, is the fact that **for many people in the area, the provision of RAPS systems was considered a “stop-gap” measure until grid power eventually came, a conviction still held with intense certainty by many.** So there is really little commitment to the whole process by a significant proportion of the population. This is reflected in the fact that few settlers set aside money for the inevitable replacements and equipment failures, and the spate of battery failures lately has re-activated calls for government provision of power, *any power*, at *urban rates*, and for the provision of grid power to the area.

This situation is similar to that reported for other Remote Australian Communities (Lloyd et al 2000).

## System Configurations

In order to address many of the following issues, the different configurations (topologies) of RAPS systems need to be explained, as these have an important bearing on the nature and appropriateness of the components selected.



**Figure 26** The 3 configurations employed in RAPS systems. In the parallel system the inverter is also a battery charger (note double ended arrows between inverter and battery).

There are 3 primary configurations (Figure 26).

The first, or **SERIAL configuration** is the simplest, wherein the AC output to the user **always** comes from the inverter, and the inputs to the battery bank are always DC, either from renewable sources and/or a battery charger connected to the generator, or, in some cases, a DC generator. It has the advantage that there is never any power interruption (switching spikes etc) when the generator is operated, and it can accept any appropriate DC input. With modern inverter technology, this configuration can handle loads in the several KW range. There is a degree of disagreement about the overall efficiency of such a system, but for most households there is seldom need to run a generator to handle household loads if the inverter is sized correctly.

**Switched system.** Effectively identical to the serial system, with the difference that the generator is exclusively AC, and when it operates, the loads are manually switched to the generator, which uses excess capacity to charge the battery through a dedicated battery charger. Main issue is that the switching operation generates spikes and interruptions to the power and this can be detrimental. Hard to effectively size the generator.

**Parallel system.** Essentially the same as a switched system, but it uses a far more sophisticated “**interactive**” inverter, which is also capable of operating as a battery charger. The generator (AC only) continues to supply the house power when it operates, and the inverter balances the power loads to charge the battery. If the loads exceed the generator’s output, it will switch from charge mode to inverter mode to supply the power shortfall. Switching between inverter and generator output is (or ought to be) seamless, as it is electronically controlled.

Which system is selected really depends on the nature and size of the loads to be serviced and the design philosophy of the system designer, with the switched system being the least satisfactory. Series configuration is perhaps suited to smaller systems and parallel configuration, to larger ones.. The

serial system offers the benefit that a much higher efficiency DC generator can be used as the charging backup, provided

there is no requirement to power large AC loads. Simple inverters are far cheaper than interactive units, so system costs can be lower.

#### Choice of Battery types.

As ever, you get what you pay for. Excluding batteries which are really automotive or heavy transport types, which are **not at all** suitable for RAPS service, we are left with a choice of 4 types (in order of cost). Flooded cell Lead-antimony (BP-PV STOR, Battery Energy - Suncycle), Tubular plate cells (lead-calcium) - Century Yuasa SSR series, Gel cells ( Battery Energy Sungel, Sonneshin) and Adsorbed Glass Matt (Tudor, Eagle Picher).

As the survey has indicated, the basic flooded-cell batteries are perfectly capable of providing good service, but require a high level of vigilance to prevent damage and loss of capacity. However they are the cheapest and commonest. Next, the Century Yuasa tubular plate batteries (actually they are fork lift batteries) seem to be more resistant to mishandling in this environment and show a lower Peukeut effect. Tubular plate batteries tend to come in 3 cell package (6V terminal voltage), in a steel case.

The benefits of fitting a de-sulphator to these cell types is moot, regular equalisation is by far the most important issue in maintaining their capacity. Fitting “gas recombinant” caps (Hydrocaps) to flooded cell batteries reduces the need to top up the electrolyte with water by about 95%, and as well reduces the amount of hydrogen gas vented by about the same amount, but this technology does not appear to be readily available in Australia (and cannot be fitted to many types of flooded cell batteries (Century -Yuasa) which have unusual cap designs).

Needless to say, battery types must never be mixed in a system, as each battery type has different charge requirements. Old batteries and new batteries must not be mixed either, as the older batteries will have a lower capacity than the new, and will cause the new batteries/cells to loose capacity rapidly. Hence, for the Daintree lowlands, we will need to maintain a collection of second hand batteries/cells suitable for replacing those which fail, as an interim measure for householders.

Gel cells, while “maintenance free” are fairly delicate things, expensive, and really are not appropriate for RAPS systems, as their primary advantage is resistance to



vibration and indifference to mounting position – not really issues for a household RAPS system. Overcharging can damage them permanently, due to the creation of voids in the gel. AGM cells are also vibration-proof, position indifferent, but can't be damaged by overcharging. They are more the “maintenance-free” battery, but cost correspondingly more. From this study, gel cells to appear to benefit greatly from the action of the de-sulphator, and it is likely that AGM cells would benefit likewise.

Second hand Telecom batteries are not suitable, as they are designed to stay on float for most of their working lives, and are subject to occasional “pull-downs” when there is a power failure. They die quickly under true deep cycle conditions.

With the move to higher voltage battery systems (120V), there will probably be a move to gel or AGM cells, despite their higher costs, as the battery maintenance requirements of 60 flooded cells becomes a bit onerous.

### **Battery Sizing**

Battery sizing is a very inexact process. Unfortunately most installations appear to have been built around the installer's choice of battery; for larger users, a 24V configuration is chosen, while for most a 12V configuration (using the same cells) is used. Very few users have 48V systems. Nominal 1000 amp hour battery capacities are the norm for all systems.

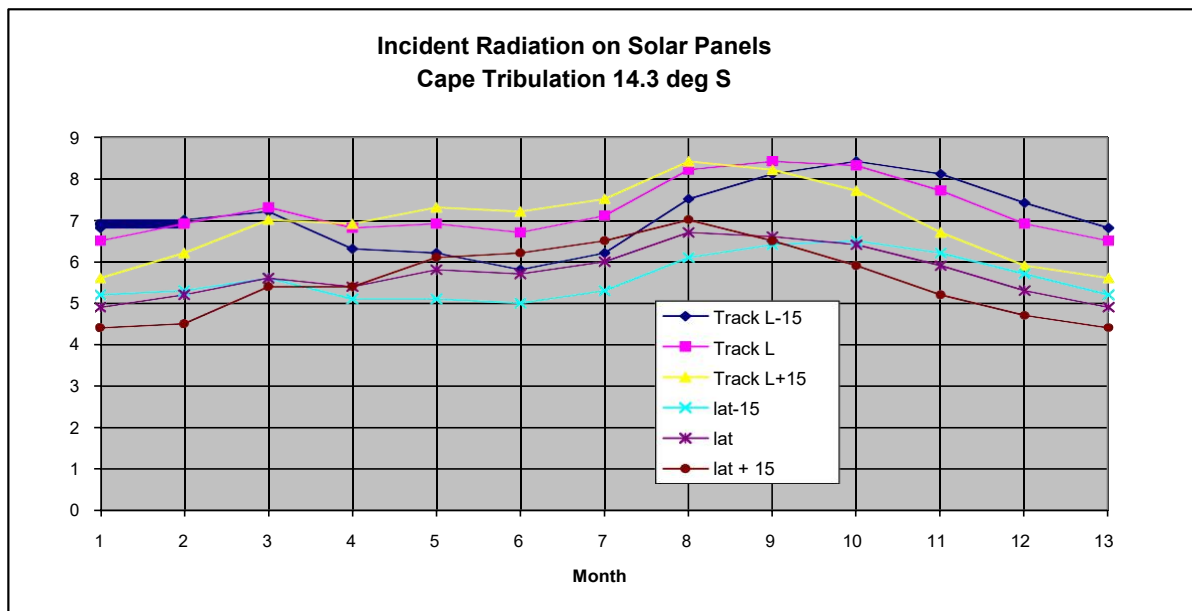
“**Autonomy**” is the number of days that the battery bank is expected to supply a normal day's power useage - this term is much used in the US renewable energy scene. Currently the general assumption appears to be – for a power use of 2.5 KWH/day a 12 V system is appropriate, giving a draw of 208 amp hours (20% of a nominal 1000 AH battery bank. 5KWH at 24V and 10 KWH at 48 V produces exactly the same AH draw (208AH). This would theoretically give 3 days autonomy to a discharge limit of 60%. Our experience is that battery banks capable of storing more than 1 additional day's power requirements, in the Daintree environment, are difficult to keep fully charged, and degrade rapidly. Most battery systems here cycle at about

30-50% charge each day.

## Solar arrays

### Array angle

As has been previously mentioned, solar arrays in the Daintree are almost universally mounted on fixed roof mounts at an angle of 15 to 30 degrees. This appears to have been adopted, so that the panels “self clean” during rain (G Behrendorff, pers. comm) Only two systems employed solar trackers – one a home made unit, and the other has 3 commercial Suntron trackers, both these systems were installed by their owners.



**Fig 27 Effect of PV array angle versus month on incident solar radiation** at Cape Tribulation, for both fixed arrays and single-axis trackers with the panel array facing true north. The effects of incorrect array angle on received solar power can be quite dramatic. The three lower traces are for fixed arrays, the top three traces are for a single-axis tracker (which also require seasonal adjustment). The angle of the array is commonly specified as the same angle as the latitude of the site, plus or minus 15 degrees, depending on the season. Cape Tribulation is 14.3 degrees south, and the 3 angles would be 0.5 deg (lat-15), 14.3 (lat), and 29.3 deg. (lat+15) for summer, mid season and winter respectively. Y axis = KWH/ m<sup>2</sup>/day falling on the solar collector. X axis – month (Month 13 = Jan for graphical completeness) The solar constant - the amount of solar energy received on 1 square meter of horizontal surface - is approximately 1 KW/ m<sup>2</sup> (remember that the collector only yeilds 15 to 18 percent of this figure as electric power). (data produced with “Solar Sizer” - Solar Energy International, Carbondale Co. USA.)

This roof mount angle is also the optimum setting for mid-winter, which in the Daintree corresponds to the period of best insolation. As there is no provision made for the householder to seasonally adjust the angle, it means that the solar panel

effectiveness is reduced by a significant factor for most of the year. This has a significant bearing on the charge state of the batteries, especially considering that summer is probably the period of highest energy use (particularly for fans), and the level of direct beam irradiance is at its lowest.

The effect of the array angle can be understood by looking at the captured solar radiation for the year along the line “lat + 15” degrees (Fig 28 above) . Here the solar insolation varies from a maximum of 7KW/ m<sup>2</sup>/day in August, to a minimum of 4.3 during December to February, a 39% reduction in solar energy. Shifting the array to “lat-15” degrees (which is almost flat) will increase the captured energy by 1 KW/ m<sup>2</sup>/day, or a 15 percent increase for the same period. These comments assume that the array is facing true north, which many arrays are not (and their outputs would be degraded as a result). The optimum array angle for any time of the year can be easily estimated by looking at the angle required for maximum output at that month. With an adjustable array – one could in theory optimise the positions each week – but the gain is usually not worth the effort, and 3x a year (Dec, Apr, Oct,) will have a major impact on energy availability.

While a single axis tracker will yield an average 25% increase in efficiency (or the equivalent of adding 2.5 panels in a 10 panel array), with present costs and designs, it is probably not economical, and it adds a significant maintenance component, which would not be acceptable to many householders. A 2-axis tracker (which faces the panels perpendicular to the sun under all seasonal conditions) exposes the panels to an almost constant 8.4 KW/m<sup>2</sup>/day, throughout the year, a gain of over 40% over the fixed array in summer, however it is correspondingly more complex and expensive.

Following from the above, the increase in available solar power from having easily adjustable roof mounts would more than justify the minimal costs of these mounts. The seasonal shifting of the angle could be associated with cleaning the panels and general checking of wiring and roof structure (something that rarely ever gets done). Adjustable mounts are simple, and if

properly designed, are quite cyclone proof. This all, of course assumes adequate solar exposure.

**Trackers.** (see Appendix 2 Fig 3) Regrettably, the technology available in Australia for “active” trackers is poor. The Suntron Trackers are well constructed, but the control electronics fail repeatedly and the larger tracker has serious bearing design problems. The company is now out of business, and a redesign of the tracker control is presently being undertaken by CTRS. Passive trackers (which use shift of gas to control the angle) are available.



Fig 28 Elevated solar arrays

For properties within the forest, only one property has mounted the array on a tall tower/ tank-stand, which increases the solar access quite dramatically.

However a **new approach** has been tried at the Cape Tribulation Environment Centre (Bat House) where a tracker mounted array can be cranked up and down a 12 meter pole using a small boat winch. During high wind conditions and for maintenance the array can be lowered to the roof level. Such array configurations maximise solar exposure and minimise the need for tree clearing, and can be made an integral part of house design and can be set up as part of the centre pole of a building.

## Solar Array Exposure

Adequate solar exposure is a major issue for properties in areas with significant canopy cover, particularly in the area bounded by Cape Tribulation Road and Buchanan Creek Road area of Cow Bay and much of Cooper Creek and Cape Tribulation. Here solar exposure (that is the number of hours that the solar array receives direct sunlight), can be as low as 5 hours (9.30 am- 2.30 pm). Most of the remainder of the properties are situated on old cleared land and solar access is not a serious issue for these properties, especially for roof mounted arrays.

## Charging

### **Solar charge Regulator** (refer to Fig 4)

The majority of regulators encountered in the study were pulse-width modulated (PWM) regulators. These control the current flow to the battery as charging proceeds by supplying it as a series of pulses of current, the duration of which get progressively shorter as the battery charges. Regulators are essential for preventing the battery from becoming overcharged, losing water through gassing and even becoming damaged from overcharging. They are primarily a protective device. With modern solid state electronics this controlling function is very easy to implement, and modern controllers are provided with a number of additional features such as an automatic equaliser timer, a battery voltmeter, current meter and more recently, some form of data logging (see Data Logging).

Of the solar charge regulators encountered during the survey, the following were the commonest:

Plasmatronics – 24/30, PL40. PL60 ( 24 households) these are fully solid state PWM regulators. The later units (PL40/60) have a high level of inbuilt datalogging and set points, which must be set on installation by the installer – a high percentage of these regulators in the study population however were operating in factory default mode – meaning that this programming had never been carried out.

BP Solar FBR40 (20 households) Similar in function to the Plasmatronics but the solar array current is relay switched rather than by solid state devices.

The Ananda 60



(4 households) are similar in function and use relay switching as well. Neither have data logging, but do have metering facilities.

In this environment, where insolation tends to be low and power useage tends to be high, a conventional solar regulator does not appear to be a particularly useful device, except when the householder is away on holidays. Every effort should be made to enhance the output of the solar arrays to reduce the depth of the daily cycling of the battery bank. This is discussed further in the sections on “Maximisers” (Maximum Power Point Trackers, MPPT’s) and bypass switches.

### Regulator Bypass switches

The fitting of solar regulator bypass switches (which as the name implies, defeats the operation of the regulator, allowing **all** the solar energy to be passed directly to the battery bank) is a very tendencious subject, with battery manufacturers being strongly opposed, and many installers (though not here) and users being resolutely in favour of their use.

Solar charging is, especially in the Daintree, at best an opportunistic exercise, and, although we have not been able to meter people’s energy useage as part of this study, it has become evident that power draw generally exceeds power available from renewable sources. This being the case, it is better that the batteries receive as much of the available solar energy as possible, and a regulator under these conditions becomes redundant (this does NOT apply to maximisers). Should the power draw fall well **below** the input charge (such when the householder leaves for vacation) then it is essential that the batteries not become overcharged for that period, and then the regulator function becomes essential.

Loss of electrolyte from over-gassing is a lesser evil to the permanent loss of capacity caused by continual undercharging, and given that many of the regulators encountered were improperly set up, we consider **chronic undercharging to have been a significant source of battery failure.**

A bypass switch coupled with an amp hour meter, and householder education on their use (**and a flashing red lamp to signify that the switch is in bypass mode!**), would conceivably save not only batteries but also generator fuel, and increase charging efficiency

### Solar Maximisers (Maximum Power Point Trackers)

Only one location used “Maximisers” (the Research Station). These relatively new solar controllers are designed to match the power supplied from the panels to the battery as closely as possible, thereby greatly increasing the charging efficiency.

Normally, as the battery voltage rises, the voltage differential available from the solar panel to force current into the battery is reduced, and the current falls off – even in high sun. When a battery is in fact fully charged, this state is in fact what any regulator achieves, but between about 50% charge and full charge the charging efficiency reduces more rapidly than it should, the charging process slows and available energy is lost. A Maximiser increases the solar output voltage so as to eliminate this slowdown. In a region such as the Daintree, where periods of clear sun are often short and intermittent, the use of a maximiser can add as much as 30% to the output of an array (this efficiency increase is a direct function of the battery state of charge and the array voltage - at high states of charge, there is no gain, but for discharged batteries, the gain can reach 30%, especially under conditions of poor solar radiation). For present maximiser designs to operate, they require the solar panel voltage to be 2x or more the final battery terminal voltage, and for this the solar arrays are wired in series, resulting in array voltage which can be as high as 110V (DC). As the panels are in series, the current available is only that of a single panel, so relatively light wiring can be employed to connect the array to the to the maximiser.

A disadvantage is that as the total array current is limited by the current of the worst illuminated panel, any shadows will reduce the array current steeply (one can see the effect of a bird flying over the array!). Bypass diodes, integrated, and/or fitted externally to the panel will reduce this effect, and power will continue to be provided (although reduced), even if one cell or panel fails.

Additionally , the Maximisers operate as a constant-current pulse-width modulated battery charger, but with the added advantage of increasing the array output. They

also remove the necessity for the normal charge controller. The most efficient MPPT's are made in Queensland (AERL), and while they are substantially more expensive than the conventional charge controller they replace, when one factors in the cost of the extra solar panel or two that the device "adds" to the system and the lowered rate of battery failure (all other things being equal), they are more than economic for inclusion in all of the Daintree installations.

### Low Voltage Cut-out

This is usually an integral part of the inverter, and is designed so that when the battery voltage drops below a pre-determined voltage for more than 10 seconds (to allow for heavy transient loads) the inverter shuts down. For 24V systems, this voltage can range between 23 and 20V. Low voltage cut-outs serve to protect the battery bank from deep discharges, and very effectively serve to warn the user that something is amiss (insufficient solar or charger input, a failed cell, or bad battery connection). If the system is used to operate DC loads as well (high efficiency refrigeration, for example) then a separate DC low voltage cut-out must be fitted (they are available from trucking equipment suppliers).

### High Voltage Cut-outs

These are usually integral with inverters (where they provide a primarily protective role for the electronics of the inverter), switching off the inverter when the battery voltage rises significantly above the boost or equalise voltage (30 + volts usually). Their activation usually indicates that something is amiss with the regulator (over-charging) or battery terminals (high resistance), and is a warning that maintenance must be carried out immediately to rectify the fault.

## Chargers

There are 4 types of charger suitable for RAPS service,

- 1) the simple 'linear' charger (which may have a greater or lesser degree of regulation),

2) the regulated charger which uses some form of electronic control to bring the battery bank to final charge voltage and maintain it there,

- 3) the inverter charger, which uses the same circuitry as the inverter, but operating in reverse, to convert the AC from the Genset, to DC to charge the battery (and perform the same functions as the regulated charger).
- 4) A fourth (new) type of charger is the “switching” (switch-mode) charger, which is similar in design and function to the inverter charger, but is specially designed to operate solely as a charger.

Simple (linear) chargers (Woods, Arlec, etc) are based on a transformer with solid state rectifiers and a basic amp meter. They have no, or minimum, electronics.

Unfortunately, as transformers are expensive, these chargers are expensive, heavy, and become very large and bulky as the output current rating increases. The Woods charger uses a lamp dimmer circuit to adjust the current, and there are concerns about the effect of the resultant output voltage waveform on battery life. Simple chargers are quite inefficient, the energy wasted appearing as heat, heating the rectifiers and the transformer. “Cooking” the charger is a quite common situation, and a number of householders have fitted fans to combat charger overheating.

Electronically regulated linear chargers have better charging characteristics than the simple linear chargers, but are large, heavy and expensive, and not that much more efficient.

Only three types of charger were found in the study – the simple “linear” charger (exemplified by the Woods series - 32 households) the linear regulated charger (Stanbury - 2 households) and the inverter/charger (Trace and Sunsine - 16 households).

In the 2 years since the study was commenced, switch-mode chargers have appeared on the market. These are far more efficient, about 90% or more, so that far less of the genset energy is spent heating up the charger. They have a better power factor, so that they can use a higher proportion of the generator output. More importantly, they are far smaller, lighter, and are able to supply charging currents that are far more appropriate to the 1000 AH battery banks

used in RAPS systems, currents of the order of 50 to 80A at 24V. They also cost about the same as the linear chargers. On the

negative side, they are far more complex, much the same level as an inverter, so need to be kept “visitor free”. (see “Unwanted visitors”)

**Charger size** - basically the bigger the better for RAPS systems, assuming that the charger has electronic controls that regulate the charging process. All new and refitted “parallel” systems should have separate electronic switch-mode chargers, regardless of the type of inverter. Under this arrangement, the inverter provides the AC power to the householder **all** the time (and as most inverters have peak ratings of 3,000 watts or more, it is unlikely that the capacity of the system would be exceeded by normal domestic use). An extension cord can always be used to supply power to high power tools directly from the generator. Having the inverter on all the time, eliminates problems associated with switching over from the inverter to the generator and back again (surge failures). As the AC quality from the 3000 rpm generators is often very poor, this also eliminates this frequent cause of appliance failure.

More importantly, a high current switch-mode charger, say 50A at a nominal voltage of 24V requires 1320 W (at an efficiency of 90%) , which provides a reasonable load on a 5KVA genset (assuming a charger power factor approaching 1). A 20A linear charger is a third of this figure. Low genset loading causes engine problems, especially for diesels, and is highly fuel wasting. Ideally a genset should be loaded as heavily as it will take for optimum fuel efficiency and the faster a battery charges, then the shorter the running time. Lead acid batteries can take as much current as you can give them in the initial charging period, and ideally 100A chargers should be installed where possible for 1000AH battery banks.

A useful reference is the “ATA Battery charger buyer’s guide” (refs).

### Battery Equalisation

Equalisation is the **deliberate overcharging** of a battery string to ensure that **all cells are brought to gassing voltage and maintained there for several hours**. This ensures that both the highest and lowest capacity cells in the string are brought up to gassing voltage, and by holding at this state for



several hours, the electrolyte is well mixed by the gassing action, and any stratification of the electrolyte is removed (particularly important for large cells) so the charging process is complete for all cells.

Adsorbed Glass Matt (AGM) cells can be equalised, and H-O recombination to form water occurs directly in the cells. Gel cells **cannot be equalised in the conventional manner** – as attempting to “gas” these cells would damage them - the electrolyte is immobilised as a gel and can’t stratify or circulate (and will create permanent voids (bubbles) which reduce the battery capacity). However they do require a “soaking” charge that serves the same purpose – the parameters of this charge should be available from the battery manufacturer.

From the results of the study, it is very evident that equalisation of battery banks is a critical and often neglected issue. Most observed catastrophic battery bank failures were the result of householders failing to understand the necessity of regular equalisation. Changes in the composition of households (for example, the member who took prime responsibility for the system, leaving) resulted in some of the worst examples of battery failure seen in the study. Householders who regularly ran their batteries very low (in the absence of a low voltage cut-out), suffered severe battery failure, as did many who attempted to depend entirely on PV array power without backup charging.

Poorly set up regulators of course were a contributing factor in some instances.

Many regulators have an equalisation cycle that is automatically activated by time, but as the opportunities for PV charging is not very predictable or reliable in this region, the opportunity to equalise during the set time may pass, it does not re-occur until the next programmed period, **(and the householders rely on the idea that when the little red “equalise” light is on, the equalisation process is happening, even though, in fact, nothing is happening at all)**. The best that we can presently expect from “automatic equalisation” is that it warns the householder who must start the generator in the absence of adequate solar input, and monitor the process.

### **Gensets.**

**Genset Design** – 1500 vs 3000 rpm. Most systems, both petrol and diesel have single cylinder air cooled engines running at 3000 rpm. These are cheap, and require a small 2-pole alternator for a given KVA output. They are also

correspondingly noisy and

because of the high revs, relatively short lived. Gensets (usually diesel) operating at 1500 rpm, are physically much larger for a given power output, require a far more expensive 4 pole alternator (to produce AC at 50 Hz at half the revolutions), and are relatively fuel efficient. They also have very long service lives, 10 years between major service being normal for such a generator in solar-RAPS service. They are correspondingly expensive. They are also significantly quieter.

Multiple cylinder engines (almost always water cooled) operating at 1500rpm, are quieter yet, and because 2 or 3 cylinders are used, produce far more power than a similar sized single cylinder engine. (for example a Yanmah 3 cylinder w/c diesel)

**Remote electric start** capabilities are becoming imperative, so that the generator can be turned on and off automatically by the RAPS controller or timer. Where the building housing the RAPS system is some way from the main house, a remote start/stop facility makes sense in poor weather. A serious disadvantage of remote start systems, is that routine generator maintenance can become neglected, and short of running out of fuel or oil, the generator will tend to be ignored. So these systems would have to be integrated with appropriate sensors and detectors (fuel level, oil pressure and maintenance timer) (see “Metering”). Remote starts are only really satisfactory for high quality gensets (1500 rpm) – cheaper gensets do not have the interlocks (oil pressure) required for reliable operation.

## DC Generators

Despite these being available in one form or another for the past 10 years, they have not been taken up by solar installers and designers (probably because Switched or Parallel configurations are a de-facto standard – it being assumed that everyone needs to run a high power device (5KW or more) fairly regularly – which is moot). **Direct DC generation eliminates the need for a battery charger, and hence gains efficiency as the AC generation and its conversion to DC steps are bypassed.** Simple DC generators are merely a standard automotive alternator or older style auto generator directly driven by a suitable sized engine. More

sophisticated systems have a purpose built DC generator which is capable of providing regulated currents in the order of 100A at 24/48V, and these are driven by small water cooled diesel engines. They can regulate their charging rate by a combination of running speed and

electronic DC generator control (**as they do not have to run at a fixed speed, so finishing charging can be very fuel efficient**, in contrast with present systems). (PANDA Germany).

## **Noise**

Genset noise is a recurring theme in discussions with householders. and noise is an oft-repeated objection to RAPS systems. With the exception of the larger resorts, few residents appears to have taken even minimum effort to reduce generator noise. In fact some installations appear to have been designed expressly for the purpose of enhancing the noise generating capabilities of the genset! We have seen generator systems residing under a tin roof, with no walls; residing in tin garden sheds with no sound dampening insulation and so on. The amount of strife between residents in the Daintree caused by inappropriately silenced gensets is legendary. No funds were set aside in the DRAPS program for noise control, and so it was not considered in the design. Many generators (36%) are 3000 rpm, air cooled gasoline powered units which radiate enormous amounts of noise from the actual body of the engine. 1500 rpm units (all diesel) are far quieter, but emit a lower frequency noise that can carry many hundred of yards. Water cooled gensets are far quieter yet, but are more expensive (although they can supply hot water for the residents as well – thereby increasing the system efficiency).

Commercial “silent pack” systems are exceedingly expensive (often greater than the cost of the enclosed genset), but no attempts have been made to design a cheap silenced building for this purpose. Several residents have made their own, using cement “Besser” blocks to provide the silencing for the radiated sound, and a buried “maxi” muffler (usually constructed from a discarded large gas cylinder) to reduce exhaust radiation. These rooms have been linked to an adjacent room that serves as dry storage and a place to dry laundry in the wet.

**Radiator rot.** The OEM radiators supplied with many water-cooled generator sets show severe “fin” rot after operating for as short a time as 6

months, especially in areas near the sea. The copper fins are covered only by a thin film of black paint, and the presence of salt causes rapid corrosion, and eventual failure of the radiator. Solder

coating or galvanising the radiator core before installation eliminates this problem, as does using an automobile type radiator (which are tinned). (C Slowikowski pers com.)

## **Inverters**

While we did not specifically assess inverter behaviour as part of the study, enough comments were made to indicate that at least for the two groups the simple inverters worked satisfactorily enough, however the interactive Trace and Sunsine units (16) were subject to frequent failures.

Of the simple inverters there were very few complaints, partly because the enclosure design of the inverter restricts access of insects and because many repairs can be carried out by card swapping.

Sunsine and in particular Trace inverters were subject to frequent failures – largely, it appears due to entry of insects and gekkos, as well as dust and fungal spores.

However the Trace requires removal of the inverter to a service agent for even the simplest repairs, and required shipping out-of-state for electronic repairs. Its enclosure design makes it almost impossible to disassemble for cleaning in the field. The only Trace inverter, to the author's awareness, that hasn't failed (in over 9 years) is that at the Cape Tribulation Tropical Research Station, and this is probably due to the unusually warm and dry conditions generated by the east facing "Pyramid Power System" enclosure (Fig 3 Appendix 2), which effectively "bakes out" the inverter on sunny days. The 48V Trace inverters have the worst maintenance record.

This level of inverter failure created considerable dissatisfaction with householders, and several reverted to diesel only operation during the trial.

## **Metering**

Metering (of rather lack of accessible and understandable metering) is one of the primary issues affecting householder understanding and operation of the



systems in the area.

**Meters** – amp meters, volt meters, AC frequency, state of charge, amp-hours, etc, if present in the equipment, tend to be “embedded” in a way that makes them hard to access for the normal householder (even, assuming that they could make any sense of them). Many inverters and regulators use menu-driven metering – often this is very complex indeed – and requires an understanding of the layout of the menu (or at the very least a printed copy of the menu layout – as, for instance, that provided by Trace, for their inverters see Appendix 2, and Plasmatronics for their even more complex menu, see Appendix 3). Frequently the functions are duplicated – the inverter and the regulator will both have current, voltage and state of charge information, which is confusing (especially so if they do not appear to agree with each other, as is often the case). Menu driven systems, while they can present a wealth of information (and are very cheap to implement with digital technology), can be extraordinarily tedious and frustrating for a non-technically inclined person to use, and hence tend to get ignored. They present considerable difficulties even for the average technician.

Worse, these meters are often in difficult places to access – under floors, in cupboards, in corners, along with the batteries, and access alone requires an above average level of commitment by the householder.

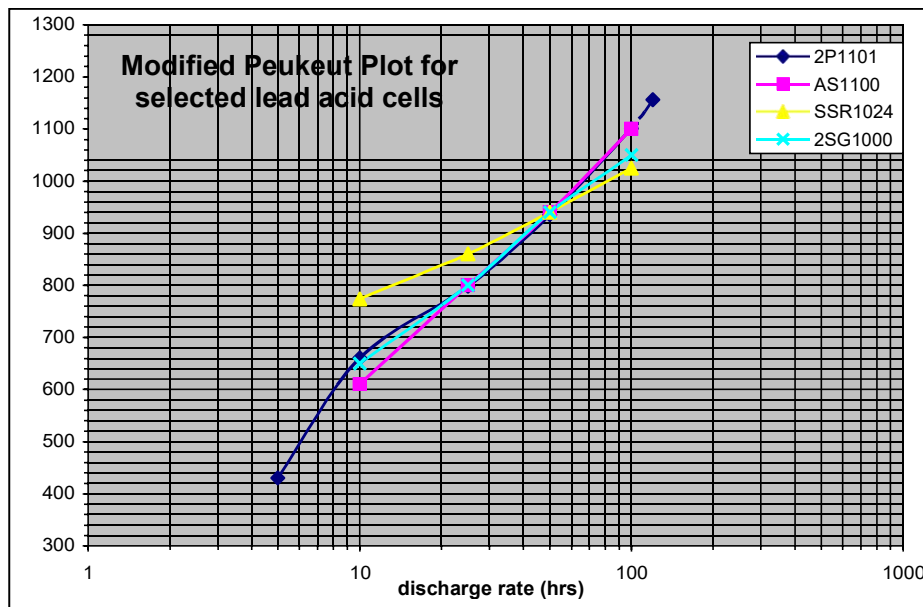
#### **Amp-hour meters** (Peukeut’s relationship)

One of the most obvious issues that emerged from this study, was the almost total lack of a reliable battery “fuel gauge” - to permit the householders to accurately monitor the amount of charge remaining in and being added to and removed from the battery.

Present technology for amp-hour metering appears to be still in its infancy. In essence, an amp-hour meter monitors the net current to and from the battery and displays the amount remaining in the battery, so providing the user with some idea of the battery state of charge and when it might become necessary to provide additional charge. Charging the batteries to equalisation voltage (for at least an hour) should reset the amp-hour meter to zero (indicating that the battery is “full”.)

However – carrying out this operation with some degree of accuracy is by no means as simple as described. As illustrated in Figure 29 the efficiency with which a battery

delivers its energy, is dependent on the rate of discharge, a relationship known as Peukeut's relationship (see Fig 5), whereby the higher the discharge current, the lower the battery capacity (or the lower the battery efficiency).



**Fig 29 Peukeut plot of cell capacity (in ampere-hours) vs discharge rate** (discharge of the total rated capacity over a designated time) of 4 battery types all having comparable published capacities, and which are representative of the battery types used in the Daintree area. Rather than plotting these curves as a log-log plot, the Y axis has been plotted on a linear scale to visually enhance the differences between the cell types. It can be seen that as the discharge rate increases (moving to the left on the X axis) the rated capacity falls sharply.

For the BP PVstor 2P1101 with a rated capacity of 1101 amp hours at the 100 hour rate (10A continuous drain, C100), the capacity collapses to 445 AH at a current drain of 220A (C5). (for a 12V system, this represents a total load of 2.64 KW, not all that unusual in a RAPS system. The tubular plate Century Yuasa SSR series batteries (yellow) have a far flatter curve, and hence their capacity is less affected by discharge rates.

**This graph indicates clearly that the published battery capacity is at best nominal, and householders have an unmet expectation that they have more power storage than in fact exists.**

As part of RAPS system design, stated battery capacity should be de-rated by at least 30% to reflect the effects of higher than specified discharge rates.

It is essential to understand, that the Peukeut effect ONLY applies to the DISCHARGE capacity. The CHARGE efficiency remains unaltered.

It has been suggested that batteries that show a narrow Peukeut shift, have a shorter cycle life (Max Enfield pers comm.). This however may not apply to tubular plate cells.

This relationship does not appear to hold for charging, and lead-acid batteries appears to have a roughly constant charge efficiency of about 88% requiring a 12% **overcharge** to charge the batteries fully. Thus a truly effective amp-hour meter must compensate for **both the charge and the discharge rate** that the battery experiences, and the discharge compensation factor will depend on the nature of the battery technology used – as is evident in the family of curves in Figure 29 above. With modern micro-processor based electronics, providing this compensation automatically is quite simple, but despite searching, we have only found one manufacturer's product that does in fact claim to do this (Victron BMV 501).

Several of the inverters have a “% meter” on the front panel display (Selectronics and Latronics), which purport to act as an amp-hour meter, being set to 100% when the battery voltage reaches equalisation voltage. The PSA interactive inverter has an amp-hour counter function incorporated into the LCD display. It is reset upon equalisation, but there is no compensation, and the figures are an approximate guide.

The Choice Electric (Brisbane) controller provided with the original Research Station's Pyramid system does have a basic amp hour meter, and while it does not compensate for load or charging rates – we still use it on a daily basis. However, if equalisation is not carried out sufficiently frequently (2x a week) - then the meter readings rapidly become seriously misleading.

Presently there are 3 different amp hour meters available, the Cruising E meter (aimed for the boat market) and the Trimetric / Trace meter, both are considered excellent, but none compensate automatically, although the Trace version of the Trimetric can have various fixed discharge compensation rates programmed in. The Victron BMV 501 does have compensation capabilities. None of these were encountered in the survey.

**A suggested Metering system.**

A common metering system, preferably preferably with large LED numerals (so that it can be read under any lighting situation – LCD's are frequently damaged by humidity in this environment, and usually need a torch to view them), should be

installed in an accessible prominent place in the house. Access to each parameter being metered should be by a dedicated pushbutton for each. The user should be able to control the generator from this site, as well as enter battery equalisation mode. All the metering and control merely requires a small multicore signal cable to the battery bank, which can be 10's of meters away. Having it set up this way generates and maintains householder interest and involvement in their systems (Selectronics has a "remote", which has some of these features).

**Metering** objectives - not all of these would be

necessary Array voltage (for Maximisers)

Charge voltage

Array current (for Maximisers) Charge current Array

current Amp hours (IN, OUT) (compensated)

Load current

AC Load current or watts

(and analog AC current meter can be quite useful in looking at AC load

changes)

Controls -

genset on/off Equalise (preset timing) on/off regulator bypass

**Warning flags** (light-audible alarm)

low battery voltage Low battery Cutoff High battery

voltage Equalisation required.

Engine problems

Service timer Regulator bypass on.

Such a system would prove more than adequate and from experience, most householders would make a regular habit of checking the meter several times a day when home, and so would rapidly start to learn to "drive" their system.

**Data Loggers** Data logging capabilities are already available in solar controllers such as the Plasmatronics models, and it appears that some level of logging capability is being made mandatory for new RAPS installations, some with telephone modem connections to the installer. Intelligent use of a well designed logging system can be of inestimable value to the repairer and

to the committed householder, provided that access to the data and its interpretation is relatively straightforward. Unfortunately



most menu driven systems are difficult to use, and connection to a PC is difficult as well. Having loggers as an integral part of specific devices (solar charge controllers) appears foolish, as complete logging will require access to battery, genset, inverter as well as insolation and loads, something better accomplished by a purpose built device. Reliance on a modem-connected logger is an invitation to disaster, as the householder will feel that “they” are watching the system, when in fact a telephone line failure, or pure cupidity on the part of the installer, may mean that the system is unmonitored, and hence fails, a failure that could have been prevented by timely action by the householder. Besides, phone monitoring is an additional cost to the householder.

Current rebate schemes, such as the REDRS, do require logging, but evidently this can be satisfied with a simple DC logger and a KWH meter for AC (M.Enfield pers comm.).

### **Installers**

As mentioned in the introduction, there existed a dearth of competent installers at the beginning of the program and those installers that still operate, appear to regard solar system installation as “**just another business**”. In the USA there is a real camaraderie between a high percentage of installers, as perusal of magazines such as “Home Power” will attest. That doesn’t appear to be the case here, and there does not appear to be much interest shown by installers in the philosophy and environmental aspects of renewable energy, let alone developments in the technology.

### **Unwanted visitors**

Living in the rainforest means that there are many animals (and fungi and plants) who will share our living space, which includes electronic equipment.

**Gekkos** These little reptiles are the bane of many systems, especially those using Trace Inverters, and they can damage many components of a system by entering the electronics and laying eggs on circuit boards. Their

droppings and dead bodies short out high impedance circuitry, adding to the impact of the ever present rain of fungal spores.

**Visitor Exclusion** - primarily cockroach and gekko proofing of equipment designed for tropical environments is essential, does not appear to feature in designs. Some inverters such as Selectronics are “gekko proof” as a function of their design, others such as Trace inverters and BP regulators are not. Gekkos also live in solar panel connection boxes, along with spiders (and wasps), and while they are unlikely to cause immediate and spectacular failures, as happens with inverters, their waste products rot and corrode the leads and circuit board traces, especially during the wet season. Attention to visitor proofing inverters and the like should be carried out at the installer’s workshops before they are brought to the Daintree, the savings in maintenance visits would be considerable. Trace states that all of their inverters must be properly screened by the installer (why not by Trace?? - as it involves complete dismantling of the unit) if they are to be installed in a “vermin” prone area (or the warranty will be void).

Fungus and humidity are also major destroyers. Equipment put on the **outside** walls of buildings will have a high failure rate as they will **often cool below dew-point** temperature at night, and get quite wet with water condensation. Having a DC or AC voltage present at the same time as the film of moisture, leads to electrolytic corrosion, which can cause quite spectacular damage to circuit boards. The presence of fungal spores only accelerates this process. (The persistent failures in the Daintree of AC powered whitegoods such as Fisher and Paykel washing machines, is in fact due to this cause).

RAPS related electronic equipment should be mounted inside the living space of buildings – this not only benefits the equipment, but makes the user more aware of it. An alternative is having the equipment mounted in a suitable small weatherproof enclosure, which can get hot in the sun or under normal operating conditions. The “Pyramid Power” system (which was the nucleus of the research station’s present system) has this quality, and in its 9 years of operation there have been no moisture related equipment failures.

**Fungal Growth** Unprotected alternators tend to fail due to fungal growth on the stator wiring. Unfortunately unless “**tropic proofed**” systems are specified, **at the**

**time of purchase**, systems with insulation suitable for temperate climates will be supplied. Systems can be tropic proofed in Cairns – but this is best carried out **before** the genset is installed. It also often unearths failures in genset design and construction before they have had time to manifest themselves in use.

### **Co-generation** (hot water/laundry)

Some residents have built engine sheds that silence the engine and also double as drying rooms, the hot exhaust pipe passes through an adjacent room and a small fan blowing on the pipe serves as a heat exchanger. A considerable amount of energy can be saved by this arrangement (than using a conventional rotary drier), and if the exhaust ducting is well sealed, there is no reason why the drying room should be contaminated by exhaust fumes.

Water cooled engines can be used to provide household hot water by using a header tank with a heat exchanger. An appropriate thermostatic bypass valve prevents the engine from staying too cold. It can be used to top up a solar hot water system, so that in periods of poor insolation, when the solar input is poor, the generator engine waste heat can bring the water up to a useable temperature. Unfortunately, we did not encounter this form of co-generation during this study.

## Energy Conservation and Demand-side Management

One obvious method to increase system effectiveness without recourse to larger battery banks is **energy conservation**, but there seems to be very little understanding of that concept in the Daintree, and generally there is an attitude **“if there’s a socket in the wall, let’s see how many things we can plug into it”**.

This stems partly from failure of the system suppliers to educate the householders at the time of installation, a general failure of understanding by the householders about the mechanisms of conservation, and the selection of appropriate appliances.

Energy conservation is complicated by the additional issue that most appliances and electrical goods are designed for the temperate climate market. Compact fluorescent lamps, which would have a significant impact on energy use, tend to fail rapidly in this environment, because of the humidity and fungal spore load. The older compact fluorescent lamps that have an electromagnetic ballast, are not as efficient as the newer electronic ballasts, but they are less prone to failure. The electronic ballasted units can often have lifetimes of less than a month, which makes them exceedingly uneconomical to use. (the solution – re-manufacture by some local entrepreneur, as Rainbow Power Company is presently doing, could be the basis of a good small cottage industry ).

**Phantom loads (appliances that consume power when the device is “off” ) are becoming a major energy consumer** that is having a big impact on RAPS systems. TV, microwave, Hi Fi, Stoves, radios, video recorders, washing machines etc, especially those with remote controls and “instant-on” features consume very substantial amounts of power when not actually in use. For example a video system which uses 25 watts of power in the “off” condition, will require 1.1 amp current from the batteries for a 24V system. In 24 hrs, this translates to approximately 25 AH x 24 or 600 watt hours (enough energy to bake 2 standard loaves of bread in an electric breadmaker), for no purpose at all (other than to avoid a 5 second wait to have sound, TV or whatever). Add the power draws of other devices – microwave oven, stove timer, washing machine etc, and we can find that the equivalent of the

energy from 2 solar panels is **providing no effective return**, in terms of battery charge.

The solution is to turn everything off at the wall when finished using it.

With the advent of internet connectivity, many Daintree households have **computers**, and very few have laptop computers, most plumping for the desktop variety on the basis of price and added “features”. Desktop computers consume at least 6-10x the energy of a comparable laptop ( 200 to 300 watts), and tend to be left running for substantial periods of time when not in use, becoming very expensive and power hungry “phantom loads”. Laptops consume 25-35 watts, provide essentially the same features as a large computer and most have some form of “sleep” mode which only consumes ½ watt or less,. Newer flat LCD screens reduce desktop computer power requirements by about 100 watts - but their survivability in this environment has not been determined yet.

**Refrigerators** are also a major energy sink, as the majority of electric refrigerators available in Australia for domestic service are highly energy inefficient, despite the star ratings, and consume about 1.5 KWH per day. Refrigerators with cyclic defrost, can use very high amounts of power for the defrost program. Refrigerators suitable for RAPS households that are available in the USA (Sunfrost) can use 1/5 of the energy of a standard domestic refrigerator (250 – 300 WH).

**Ceiling fans** are another major energy drain, and are exceedingly inefficient compared with simple desk fans, which will do much the same job for 1/4<sup>th</sup> or less of the energy cost.

But overall, the **major issue** is the **expectation** that just because there is a power outlet – **anything and everything** can be plugged in, and that the **system should magically produce the power to support them**. If this happens during good weather, then the illusion can sometimes be maintained for a month or so before the system crashes. This was amply demonstrated at the Diwan Community Centre several years ago, where a new solar system was installed followed by the installation, in quick succession, of ceiling fans,



a large computer, refrigerator and electric kettle AND a photocopier which caused the rapid demise of the entire system (and they were supposed to be providing an example to the community!)

Timing of doing chores is critical, if the weather is fine and there is ample solar energy, then energy intensive chores can be carried out, or when the generator is running (especially as no more than 1.5 KVA of the generator's capacity is used for charging batteries, the rest is available for high-energy requiring tasks). This requires planning, and unfortunately is not always compatible with attempts to live a 21<sup>st</sup> Century urban business lifestyle in the rainforest.

### Inappropriate/Inadequate Appliance design

As mentioned above most household appliances are designed for the equivalent of a temperate indoors environment.. The climate of the Daintree lowlands is exceedingly testing on everything, and appropriate choices and appropriate handling of those choices can have a major impact of their longevity and serviceability.

Whitegoods such as washing machines, and refrigerator/freezers tend to be constructed of unplated sheet steel and sprayed with white enamel paint. These are subject to rapid rust and corrosion from condensation and fungal spores which germinate and produce organic acids which attack the metal through the paint layer. This can happen in amazingly short periods, and the appliance can become useless, or at best highly unsightly, after a year or so. Powder-coating is as bad. Whitegoods constructed from "Colorbond" steel sheet (which is zinc-plated (galvanised) and then painted) are exceedingly robust and the cases show no destruction even after 10 years of very difficult conditions. Unfortunately, few manufacturers use Colorbond.

Many modern whitegood appliances are completely unsuited to operating in the Daintree lowlands environment, although they might operate in the drier urban conditions of Cairns or Mossman. As an example, the Fisher and Paykel "Smart Drive" washing machines, which are probably one of the most energy efficient top loading models, have a very short service life, this being due to the fact that they are "instant start" designs, and the electronics are constantly energised (=phantom load). At night, especially during the

humid periods, the temperature of the machine falls below 'dew point' and condensation forms on components such as the motor position sensor or the out of balance switch, and electrolytic corrosion rapidly occurs (as they have 15VDC across them all the time). At the Research Station these were replaced

at least 5 times (and repaired many more) before the nature of the problem became clear. Fitting an “on” light, and ensuring that the machine is turned off at the wall when not in use, has completely eliminated this cause of failure. Another example is the CleanMaid gas-electric dryer, (the power consumption of all-electric driers is so high that, except for those with large gen-sets, they are inappropriate). The computer based gas control on this brand of drier is so sensitive to earth leakage, that it won’t work even in non-condensing humidities (80-90%) without using a hair-drier to dry critical components. Short of a complete redesign, there is no easy fix. Bread-makers disintegrate, unless the oven section is kept scrupulously clean. And so on.

### **Solar “paramedic”.**

There is an **urgent** need for someone in the Daintree lowlands to take on the task of being a general information resource, emergency repair person as well as someone who can carry out preventative maintenance, regular battery testing and so on.

Unfortunately setting up to carry out such services is expensive, and such a person would need at least funding for initial equipment set up, and some amount of per- service rebate (as this is a economically depressed area). There is a need to be able to set up a bank of second hand cells for replacement of

## **Future**

### **Change in technology**

While inverters and chargers are improving, becoming more reliable and efficient, the variety (and cost) of solar panels available have not really changed, even though the number of manufacturers has increased. Other than gel cells and AGM cells, lead acid technology is still primarily based on flooded plate batteries.

Charge controllers are now smaller, cheaper and have more “bells and

whistles” but for the normal installation here these are of little consequence (as discussed earlier).

Automated or semi-automated control systems still haven't really appeared on the market – even though the technology to create them has been around for many years. Maybe we are seeing the increasing corporatisation of the solar energy business, with systems being designed by engineers who do not in fact have to live with their designs.

Automation of RAPS system is going to be the only way a householder, who really does not want to (or just is not able to) get to grips with the intricacies of their system, can successfully use a renewable energy RAPS system. But it will have to be coupled with a “teaching module” that remonstrates with the householder if they exceed system limits and capacities. Lloyd et al (2001) in their report on RE in remote communities, indicates that sophisticated automatic controls fitted to remote RAPS systems, all failed and had to be disconnected. This is probably more of an indication that we are a long way from achieving success in this field. As our study shows,

a motivated householder is far more effective than a thousand controls!

The industry trend for modern solar RAPS systems is towards the higher voltage DC systems, with a minimum voltage of 48V with a suggestion that 120V will become a future standard. This shift is partly being driven by the fact that as DC system currents approach 100A, the costs of DC controls and wiring rise sharply, so doubling the DC voltage halves the currents. Solar racing cars have led also to the development of technologies to “milk every last drop” of energy from the solar panels. High voltage systems require smaller A/H capacity batteries to provide a given power reserve.

12V 12KWH reserve – 6 x 1000 AH  
 cells. 24V 12KWH reserve – 12 x  
 500AH cells 48V 12KWH reserve – 24  
 x 250 AH cells 120V 12KWH reserve -  
 60 x 100 AH cells.

However, while for 120V there is the disadvantage of a lot more smaller cells (which if flooded cells are used, are not prone to some of the troubles of their larger cousins - such as electrolyte stratification - but are correspondingly more expensive for any

given capacity). There are other major benefits however – inverters can be smaller (as there is only a 2:1 voltage step up ratio), direct DC charging becomes simpler, IR (current related) losses in wiring is reduced 10 fold, as a load of 1000Watts at 12V requires a current of 83A, necessitating very heavy connection wire whereas 1000 watts at 120V is only 8.3 A, which can be readily carried by standard heavy gauge house wire. Contact resistance (between battery cells and wire connectors) is less critical at the lower currents, whereas at high currents it can account for very significant energy losses and heating. Maximisers are cheaper to construct, and total system efficiencies (excluding the batteries) can rise to 98% (from about 80%). Of course operating batteries at C20 or C50 discharge rates significantly increases their capacity. There are, however increased safety concerns for higher voltage systems, which will be addressed in the to-be-released Australian Standard for PV Arrays.

#### Generators and Co-generation.

Co-generation - reclamation of “waste” heat from engines/processes to do further work. Most commonly used for water heating, but it can easily extend to using absorption-cycle refrigeration for air conditioning as well. This vastly enhances the efficiency of the fuel use. A small generator may produce 5 KW of heat, and only 800 watts of electricity - that 5 KW is normally wasted as engine heat. Unfortunately while the technology to heat water is readily available, that for the absorption refrigeration is less so. With “silent pac” designs, available as an add on to many diesel engines, the entire engine, battery bank and heat recovery system could be incorporated into a building design. However, they are expensive at present, but not nearly as expensive as trying to supply the electrical energy to run air-conditioners and a HWS.

Developments in **Stirling Cycle** engines (which are external combustion devices - like a steam engine) (WhisperGen NZ) have the potential to eliminate the noise, dirt and maintenance issues of diesels (these new engines use no lubricants and are as silent as the average air-conditioner) - while providing hot water (and by extension refrigeration), The are about as



efficient as a small diesel. In addition they are DC generators with integral battery charging capabilities, so do away with the need for a charger (in parallel systems). They produce about 40A max, at 24V and have a 3 stage

regulator for battery charging. Because they are effectively noise free, they can be integrated within a house.

### Solar Panels

Present solar panel efficiencies are about 18% (single junction silicon). Using maximisers and 2-axis array trackers the output could theoretically be increased by 160% (compared to a non-tracking fixed solar panel (Fig 30) ). New solar panel technologies are being introduced which have efficiencies of over 25% (Gallium arsenide, and double- and triple-junction amorphous silicon – which work well in cloudy conditions). At present they are expensive, but as demand increases they will become affordable.

As an example, the 4 panels (nominally 80 watt peak) mounted on the vertical pole at the Bat House (Fig28) would produce 1.6 KWH, if fixed at the latitude angle of 13 degrees. Were we to add a maximiser, the output could increase to 2.1KWH, and if we were to exchange the panel material for double junction amorphous silicon, then we might expect to gain 3.8 KWh – a 237 percent improvement. Add a 2-axis tracker which keeps the panels always aligned perpendicular to the sun, we might obtain 6.3 KWH, a an energy gain of 4x. This is of course best case, but even a doubling of output would be a major advance.

Relative theoretical performance table for 2 m<sup>2</sup> panels on the mast.

| Mount               | Relative efficiency % | Si Panels alone KWH | Maximiser KWH | Max+Double junction KWH |
|---------------------|-----------------------|---------------------|---------------|-------------------------|
| Fixed 13 degrees    | 61                    | 1.63                | 2.12          | 3.81                    |
| Single axis tracker | 90                    | 2.41                | 3.13          | 5.63                    |
| Dual axis tracker   | 100                   | 2.68                | 3.48          | 6.26                    |

So, the possibility of obtaining a significant amount of solar energy from a small simple pole mounted system above the rooftop and the tree canopy, is presently fair, and with improvements to solar cell technology could become excellent. If we were able to obtain 3 square meters of active panel (the illustrated array has roughly 2 m<sup>2</sup> of active panel area for a total area of 2.5

m<sup>2</sup> ), then we would have enough power for

normal (conservative) household uses – 5.7 KWH/day with a single axis tracker and conventional single junction silicon cells and 9.4 KWH with newer multi-junction cells (equivalent to a current 24 panel (80 w) fixed system with current PV technology). Plus the wind resistance and stability for 3 m<sup>2</sup> of panel area would be about the same as for the 2 m<sup>2</sup> panels.

And no need to cut down the forest.

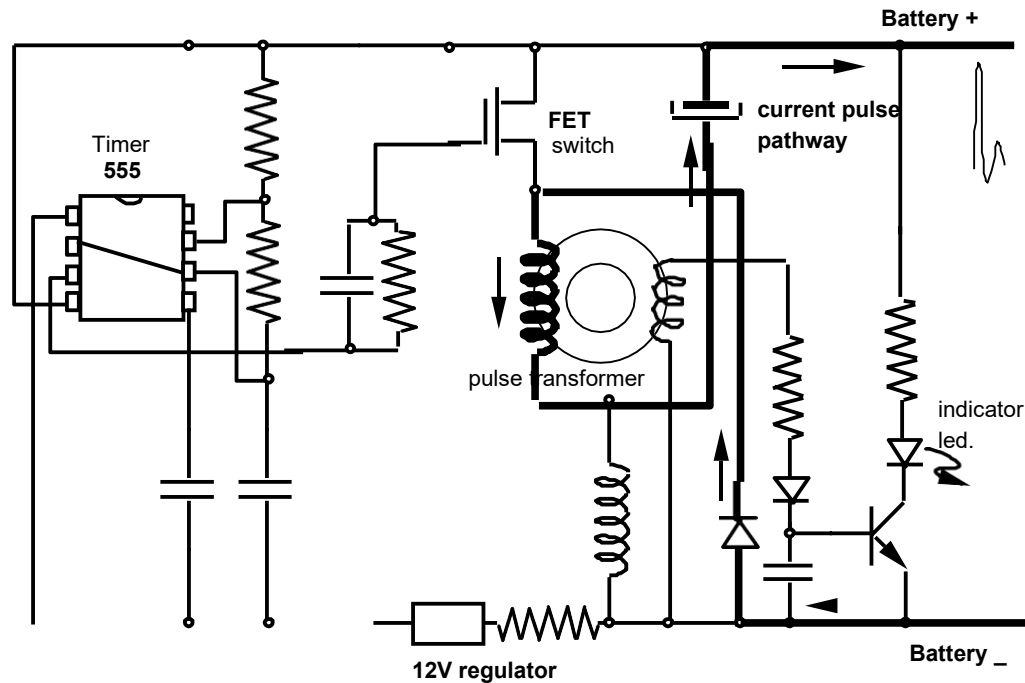
Amazing.

## References

- Anon: "Remote Area Power Supply Systems Queensland", Queensland Government Department of Mines and Energy (1999)
- Behrendorff G., "Queensland Remote Area Power Supply (RAPS) Trials", Ergon Energy (Cairns) presented at Electricity Supply Association of Australia, 5<sup>th</sup> Renewable Energy Technologies and RAPS conference, Cairns, 30 Aug 1999.
- Bond J., "Battery charger's buyer's guide" ReNew ATA Melbourne, #85, p58-62, 2003.
- Couper A., "Lead-Acid Battery desulfator" Home Power #77 2000 p84
- Davies A., "Independent power supply battery buyer's guide" ReNew ATA Melbourne, #76, p47 – 51, 2001.
- Hund T., "Battery testing for photovoltaic applications". Photovoltaic System Applications Department, Sandia National Laboratories, Albuquerque NM 87185-0753
- Lloyd R.,Lowe D. and Wilson L. Renewable Energy in Remote Australian Communities (A Market Survey) Final report,. ACRE Murdoch University. 2000
- Meinel A and Meinel M., "Applied Solar Energy" 1976 Addison-Wesley.
- Spencer H., "Daintree Power Survey" Australian Tropical Research Foundation 1994
- Spencer H and Burton E., "A survey of attitudes towards remote area power supply (RAPS) systems in the Daintree" Australian Tropical Research Foundation 1998
- Spencer H and Cowie J., "Daintree Renewable Power Survey 1999-2000" Australian Tropical Research Foundation May 2000.
- "Solar Sizer" Center for Renewable Energy and Sustainable Technology (CREST) San Francisco USA 1997. Mac Version.

## Appendix 1

### De-sulphator design and testing



**Appendix 1 Fig 1 Basic schematic of the pulse de-sulphator.** The critical components are those in the current pulse pathway (thick lines), whose characteristics control the amplitude of the pulse. The pulse transformer primary winding must have a very low series resistance and is approximately 330  $\mu\text{H}$ . The secondary serves to sample the pulse and to drive the transistor which in turn controls the indicator LED - driving the LED directly from the pulse surprisingly swamps the output pulse amplitude dramatically (there is actually very little total energy in the pulse). The diode is a soft recovery type, and the series electrolytic capacitor is a very low impedance type to provide a low AC impedance path for the generated pulse.

The de-sulphators were constructed on a 35 x 48 mm circuit board using a mix of conventional and surface mount components, resulting in a very compact unit.

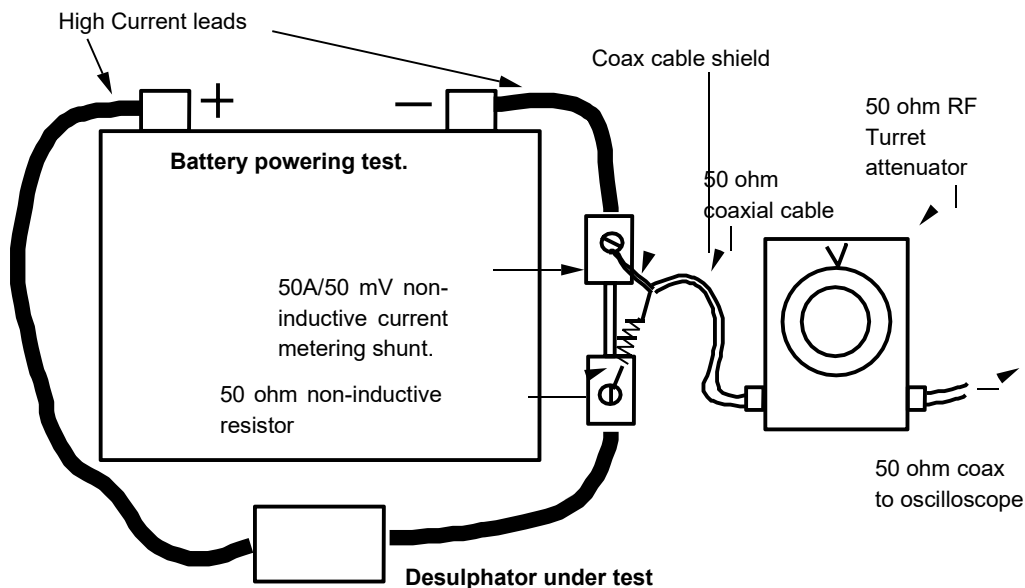
#### Pulse measurement technique.

Measuring high current pulses such as those generated by the de-sulphator is a very troublesome procedure, as the high  $dI/dt$  (rate of rise of the pulse waveform) induces the pulse signal in nearby electronic apparatus, and can

make reliable

measurement extremely difficult, this shows as variable amplitude readings or inability to reliably trigger on the signal..

This was resolved by putting a series non-inductive 1-milliohm resistance (a standard 50A/50mV metering shunt), in the ground (-ve) side of the de-sulphator lead to the battery, and sampling the signal through a 50 ohm non-inductive resistance, connected to RG 58 A/U coaxial cable and terminated with a BNC male connector. This signal was then fed via a 50 ohm turret attenuator, to the oscilloscope. In effect it was treated as a conventional 50 ohm RF signal source. If there was significant leakage of the signal, then the signal observed at the oscilloscope would have a variable relationship to the attenuator setting (as the signal would be entering the oscilloscope by other routes – as was the case in earlier attempts to measure the pulse characteristics). The observed amplitudes and the attenuator settings proved to be completely predictable, indicating that such leakage was not occurring.



**Appendix 1 Fig 2 Current pulse measuring set up for the de-sulphator.**

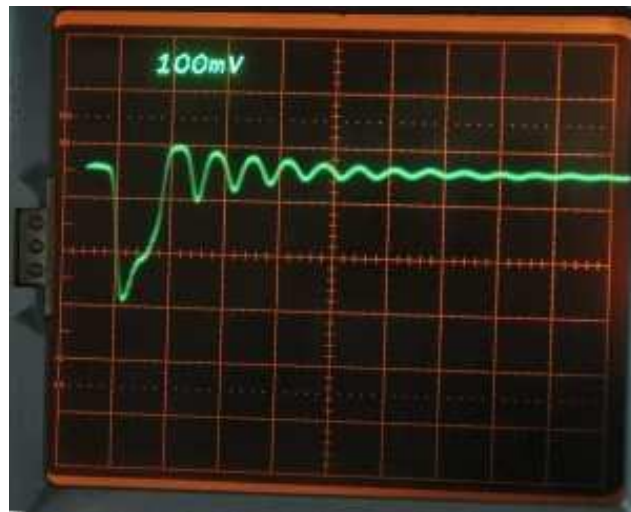
The high current lead connecting the negative post of the battery to the metering shunt should be as short as possible, as this is the “common” or ground of the system. Lengths of coaxial cables between the measuring shunt and the attenuator should be no more than 1 meter.



Original measurements were made using a 35MHz bandwidth Tektronix 930 oscilloscope, but later measurements with a 70MHz (Tektronix 7603 with a 7A15 vertical amp), doubled the current pulse amplitude (the accuracy of the earlier measurements were degraded by being band-width limited by the oscilloscope).

**Pulse polarity** All published descriptions show a positive going pulse, and this has been adopted for this design. There appears to be no available information suggesting that a positive (hyperpolarising) or a negative (depolarising) pulse would have different effects, so we chose to use the accepted approach. Depolarising pulses (effectively, brief shortings of the battery), are now employed in pulse charging systems being developed but not yet on the market – (Hund 1998), but it would require a second survey of a comparable size to this one, to establish their effectiveness.

The pulse polarity shown in the oscilloscope photograph is reversed (the actual Pulse is +ve going), as the method of measuring the current pulse reverses the polarity of the observed pulse (since the battery ground and not the de-sulphator ground is used as the measuring reference point).



**Appendix 1 Fig 3 Oscilloscope trace of the de-sulphator pulse.** Scale – 100 mV (1000A) per vertical division (the pulse amplitude is 2500A in this example), 100 nS per horizontal division. The battery resonance is clearly obvious at 17.5 MHz, and the pulse width is 100 nS.

Measured  $di/dt$ 

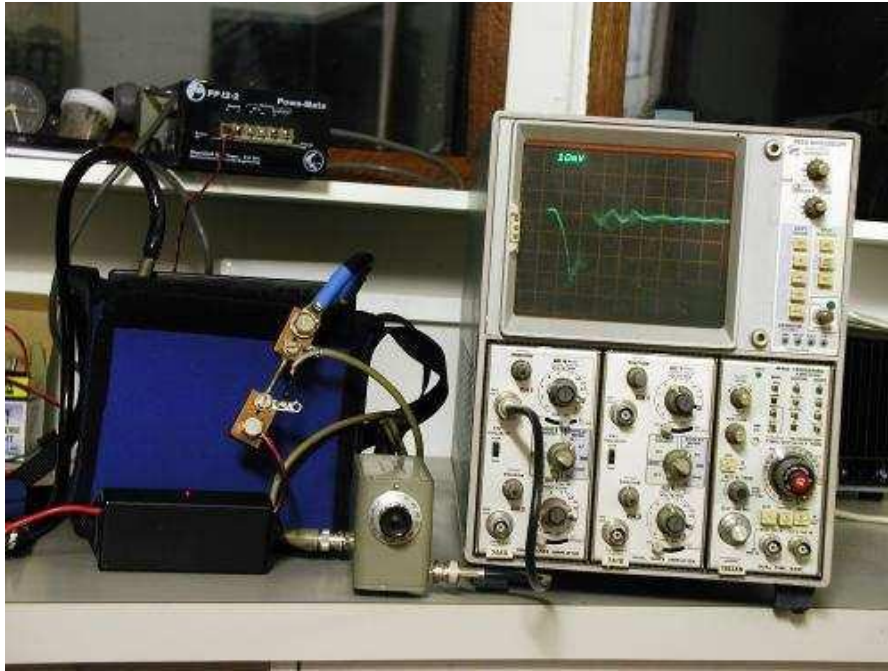
With the 70 MHz bandwidth oscilloscope, the pulses had a rise time of approximately 3 nS for a 1000A pulse, giving a rate of current rise of

$$= \frac{1 \times 10^3 \text{ Amps}}{3 \times 10^{-9} \text{ Seconds}}$$

or  $3.3 \times 10^{12}$  Amp/secs

(a figure usually observed in lightning strikes). This certainly generates an oscillatory response from the cell, with a frequency of 17.5MHz

## Commercial de-sulphator



**Appendix 1 Fig 4** Current measuring set up showing the current pulse of the commercial de-sulphator (black box lower LHS) - Oscilloscope trace is the de-sulphator output pulse without the connecting leads, and is 300A, addition of the leads reduces this to approximately 200A and reduces the  $dI/dT$  somewhat . Horizontal sweep is 50nS per division, vertical is 10 mV per division with the RF attenuator set at 20dB (giving a voltage division of 10, and a displayed value of 100 amps/cm). The current shunt and 50 ohm resistor is clearly visible.

These de-sulphators produced what is claimed to be a “ringing” pulse. The rising edge of the pulse could not be resolved with this set-up, even with the oscilloscope pictured.

## Appendix 2

### Illustrations of representative Daintree Installations



**Appendix 2 Fig 1** A basic system employing AS1100 batteries, a Trace Inverter, and a BPR4-NG controller. Not shown, Yanmar 5.5 KVA diesel generator, and 18 BP 75watt panels. This system was installed by the householder. The red and black wires running along the top of the batteries belongs to the de-sulphator. This system has been installed within the living space of the householder, and the batteries are separated from the remainder of the system in their own box.



**Appendix 2 Fig 2.** A common style of installation, in this case employing AS 1100 flooded cells (24V) a fused DC disconnect, Selectronics SA31 inverter and a Woods Dialomatic battery charger, Prostar 30 regulator all installed in a lockable garden shed. Battery vents are directly below the top shelf. (not shown is a Lister 5KVA generator and 10 BP 75watt panels). The child is optional.



**Appendix 2 Fig 3** Solar array at the Cape Tribulation Tropical Research Station. 30 BP 85 watt panels and two types of Suntron trackers. The original tracker is on top of the Pyramid Power packaged RAPS system supplied to the Station in 1995 (its alignment has drifted, as can be seen by comparison to the other two arrays.). Peak installed output 2550 watts. The front tracker was installed in Jan 03.



**Appendix 2 Fig 4** Battery located under a shed floor. Such locations (quite common in the Daintree) make routine maintenance and cleaning of the battery tops a very daunting task. At least the installer put the batteries in an appropriate plastic catch tray, which also stops organisms moving up and growing up between the battery cases, and the batteries are kept cool and well ventilated (by default). The de- sulphator is obvious on top of the batteries.

## Appendix 3

### **Maximum Power Point Tracking (MPPT) - “Maximisers”**

(adapted from Home Power magazine).

A Maximum Power Point Tracker is an electronic DC to DC converter that optimises the match between the PV Solar array and the battery bank. They are not to be confused with PANEL trackers which move the solar array to follow the sun.

So how does it work??

Solar panels put out a voltage that is somewhere between 15 to 20 volts under conditions of no load. The amount of current that they supply is a direct function of the intensity of sunlight - from say 5 amps in bright sunlight to tenths of an amp in cloudy conditions. Add to that the effect of panel temperature. The hotter the panel the lower the output current and voltage.

Batteries, on the other hand, tend not to stray too widely from their nominal voltage, so a 12 volt battery voltage will range from 10.5V (very flat) to 14.5 V (gassing).

Under charge most 12V batteries want 13.4-14.4V

So there is a mismatch between the panel and battery voltages.

**Factoid .** The **power** (which is volts x amps, and expressed in watts) of a solar panel **varies almost directly with sunlight intensity**. But the voltage and current do not, with the current decreasing much faster than the voltage until you reach very low light levels.

So we have a solar panel rated at 75 watts. This is specified under specific conditions of solar intensity and panel temperature (so called “standard” conditions, usually 1kw/m<sup>2</sup> solar irradiance and a panel temperature of 25 degrees C.) This is equivalent to 4.4A at 17V.



Unfortunately, 75 watts does NOT equal 75 watts!

Where did the watts go??

When you hook up the 75 watt panel to the battery, the panel (in bright sunshine) is putting out 4.4A. Your battery terminal voltage is at 14V (which means that the output of the panel is ALSO at 14V).  $14 \times 4.4 = 61.6$  watts - and you've lost 14 watts or almost 20% of your power. With a very low battery it gets worse, you could be losing as much as 35% of your power ( $11 \times 4.4 = 48$  watts) - at the very time when you REALLY need that power.

**Temperature.** As mentioned above as the panel temperature rises, the current falls, and so does the output voltage but by not as much. The solar panel, as it only converts about 18% of the incident radiation to electricity (you should be so lucky!), converts the rest to heat, which of course raises the temperature of the panel, until it radiates as much heat out to the environment as it receives. So a 17V panel may only produce 15V. Not much voltage "head room" to charge a battery, (a very good reason for not having the panels mounted close to the roof!).

So how does a MPPT device work?

A MPPT controller compares the output of the solar panels and the battery terminal voltage, figures out what is the absolute best power that the panel can put out, and converts the panel output voltage to get the highest current in to the battery. Put simply, it MAXIMISES the current to the battery - the rest falls into place automatically. Most MPPT's have conversion efficiencies of 92-97%. You gain 20 to 45% power in winter (these figures are for Northern hemisphere) and 10 - 20% in summer.

The optimisation works like this. A MPPT takes the 17V at 4.4 A and converts it to 5.77A at 13V which far better matches the battery. It is still producing 75w (actually you would be getting, say, 73 watts, because the MPPT device is only about 95% efficient. At 10.5 V battery voltage, you

might be getting 7A (whereas without the MPPT you'd only be getting about 4.4A!).

On cold conditions, the panel output voltage (and hence power) goes up, and with a hot panel, it falls. Without a MPPT controller, then you would lose the additional benefits from the cold panel, and you would certainly lose the power from the hot one.

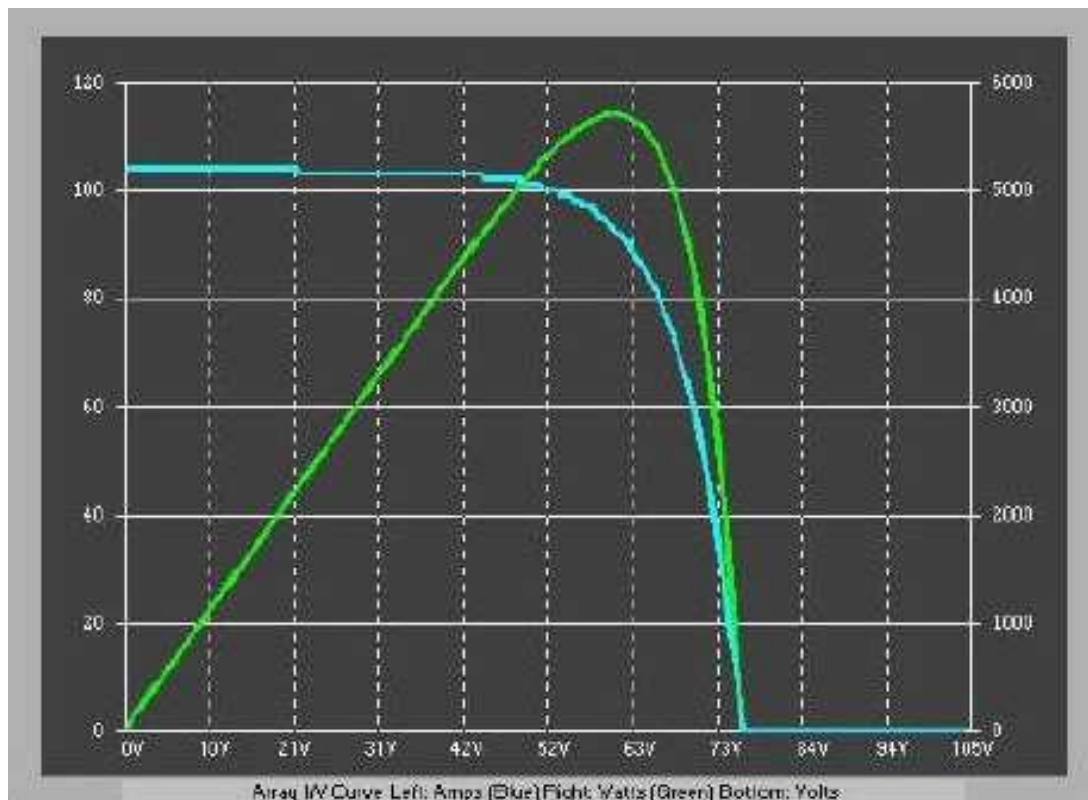


Image from “Maui Solar Software PV Design Pro”

**Appendix 3 Fig 1. Current voltage relationship of a nominal solar panel array (in this case a high voltage one).** The blue line is the current (Y-axis) plotted against array voltage (X axis). The point where the current is zero, is the open circuit voltage of the array (in this case about 75V - as the array is constructed of a group of panels in series-parallel). The current at zero volts (105 A) is the array short circuit current. The product of current and voltage (green line) is the array output power (watts- RHS). You can see that there is a definite peak in the power, the Maximum Power Point, the tip of which is where we want to operate (- in this case 5.7kw). This relationship holds for everything from a single solar cell to whopping great arrays.

MPPT are most effective under the following conditions....

Winter and/or cloudy or hazy days, when the extra power is needed the most. Cold weather (where you gain that little extra power that cold

panels deliver).

Low battery charge - the lower the state of charge, the more current a MPPT puts into them.

The only efficient (better than 95%) MPPT's on the market are made by AERL in Proston Qld. ("Maximisers") or Outback products (USA) MX60. They are expensive at present - about the cost of a panel. In the Daintree their use should be mandatory - if only for their low battery performance (and, as they are a solar regulator as well, there is a significant cost saving there). Both are microprocessor controlled.

## Appendix 4

**Other techniques for battery conservation.****Inbuilt hydrometer.**

**Figure 1** Built in hydrometer and thermometer in a Australian made tubular plate cell. The unit (Japanese made) is simply inserted between the plate array and the side of the case.

A very small number of Australian battery manufacturers in the past have included a built-in hydrometer and thermometer which can be viewed through the plastic case without opening the battery cap (Figure 1). This device permits rapid assessment of state of charge of the cell, as well as cell temperature, it also avoids the contamination problems caused by frequent opening of the cell to insert the hydrometer. Given the minor cost of such a device compared to the overall cost of a lead acid cell, their inclusion should be mandatory.

## Bubblers.

Tall format cells, such as the PV-STOR 1100AH cells (BP Solar), shown here, are prone to severe stratification of the electrolyte, especially if not able to be frequently equilibrated (the gassing created during equilibration stirs the electrolyte but may take hours to adequately mix a badly stratified cell).



**Figure2** A battery driven bubbler (small blue box) with its output tube inserted into the side of a PVStor cell. These cells have been removed from the system, but are still useable, and are being trickle charged from the main Array while being held as spares for other failing systems in the area.

We have developed a small 12V DC motor driven air-pump (a rebuilt diaphragm pump) which produces adequate pressure to pump about 10 litres of air per minute through the electrolyte column. A standard AC aquarium pump should be able to manage this. As the main issue is mixing of the electrolyte, the plastic delivery tube is passed down the side of the cell, so that the air flow acts as a pump, the bubbles forcing the electrolyte to circulate in a vertical path around and through the cell. In other words, the bubbling flow must be in the **same** path as the channels in the bottom plate that supports the lead plate assembly.

Usually 10 to 15 minutes of bubbling per cell will mix the contents thoroughly. A side benefit of bubbling in a humid climate such as the Daintree, is that it also adds water to the electrolyte (because of the extreme hydrophilic behaviour of sulphuric acid). Excessive bubbling (24 hr) can in fact cause the cells to overflow!



## Appendix 5

**Suggested Design Parameters for a Control System –**

Daily power input pattern (averaged over several weeks – sliding average by hour of day), possibly “fuzzy” or adaptive logic.

Daily use pattern (ditto) with storage of times of peak energy use so that generators can be switched on to anticipate excess loads

Battery maintenance requirements – charging parameters.

Generator control, regulator bypass, immediate or delayed equalisation.

Displays – intelligent “fuel” gauge – a fully compensated amp-hour meter, which could be used to control generator on-off times.

System warnings (as for **meters**, above).

**Basic control rationale** – if the daily solar input pattern suggests that, despite a low AH reading, there is a high probability of sunshine that day, then the generator will not be run, until late in the day. If there is a low probability of sun, then the generator would run immediately until the AH meter is reset. AH meter controls all charging behaviours, except equalisation (which is carried out on a pre-arranged schedule – using solar/generator as appropriate), and the equalisation mode continues for nominally 1 hour after equalisation voltage is reached (this resets the AH meter.).

System to “anticipate” conflicts between renewable power input and loads – to run generator in advance of needs. If regular heavy loads are expected then the generator can start in anticipation of the loads (generators usually require 5-10 minutes warm up before full load is applied).

Quiet times will be programmed in. (these are times the generator will not run – usually 9 pm to 7 am, except in dire emergency).

But, as the ACRE report pointed out, complex control systems can fail disastrously, and the technology is very much in its infancy.

Appendix 6 Flow Chart for Trace Inverter

# TRACE SW40XXI30XX SERIES INVERTER CONTROL PANEL "MAP"

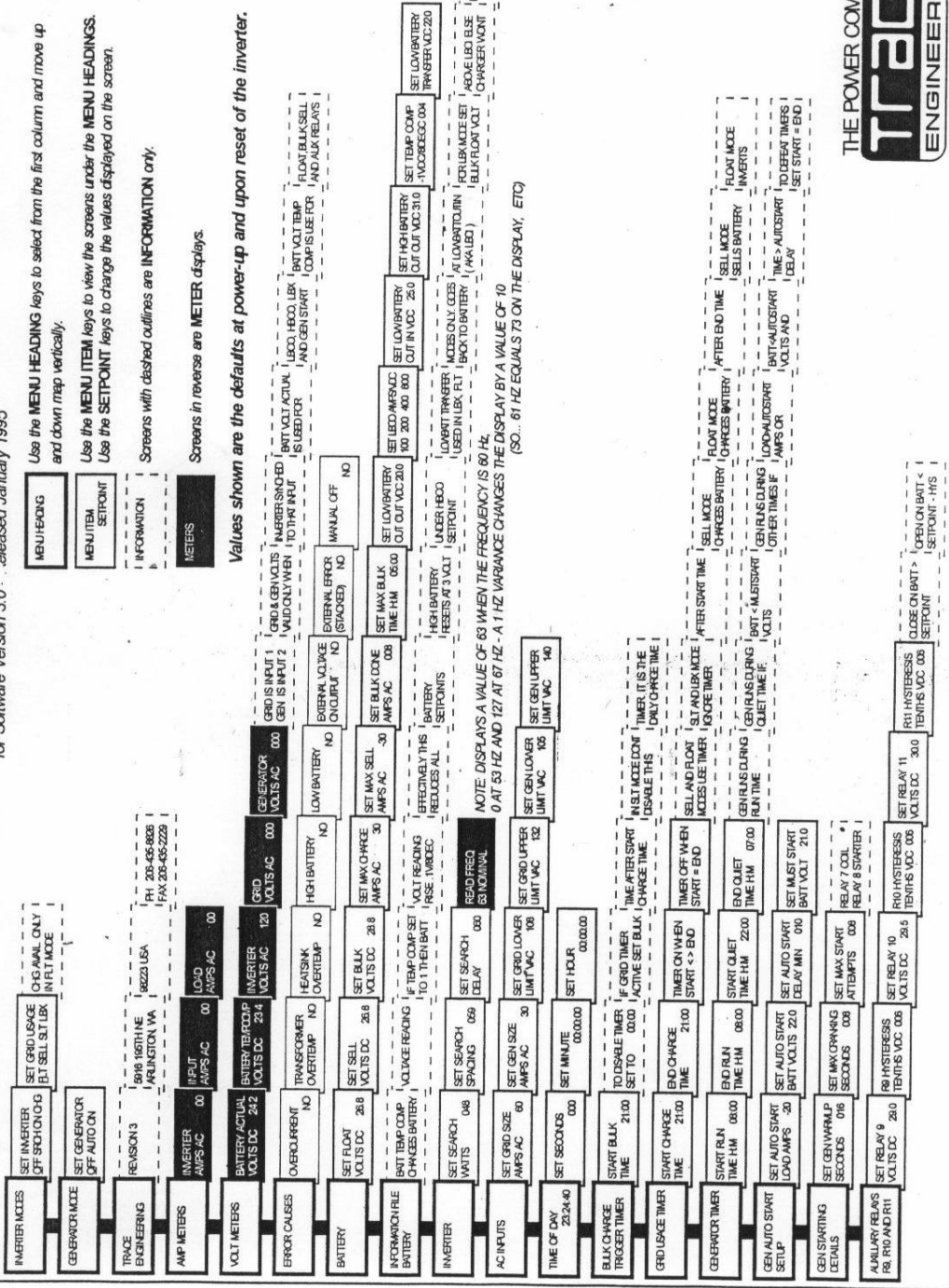
for Software Version 3.0... released January 1995

Use the MENU HEADING keys to select from the first column and move up and down map vertically.  
 Use the MENU ITEM keys to view the screens under the MENU HEADINGS.  
 Use the SETPOINT keys to change the values displayed on the screen.

Screens with dashed outlines are INFORMATION only.

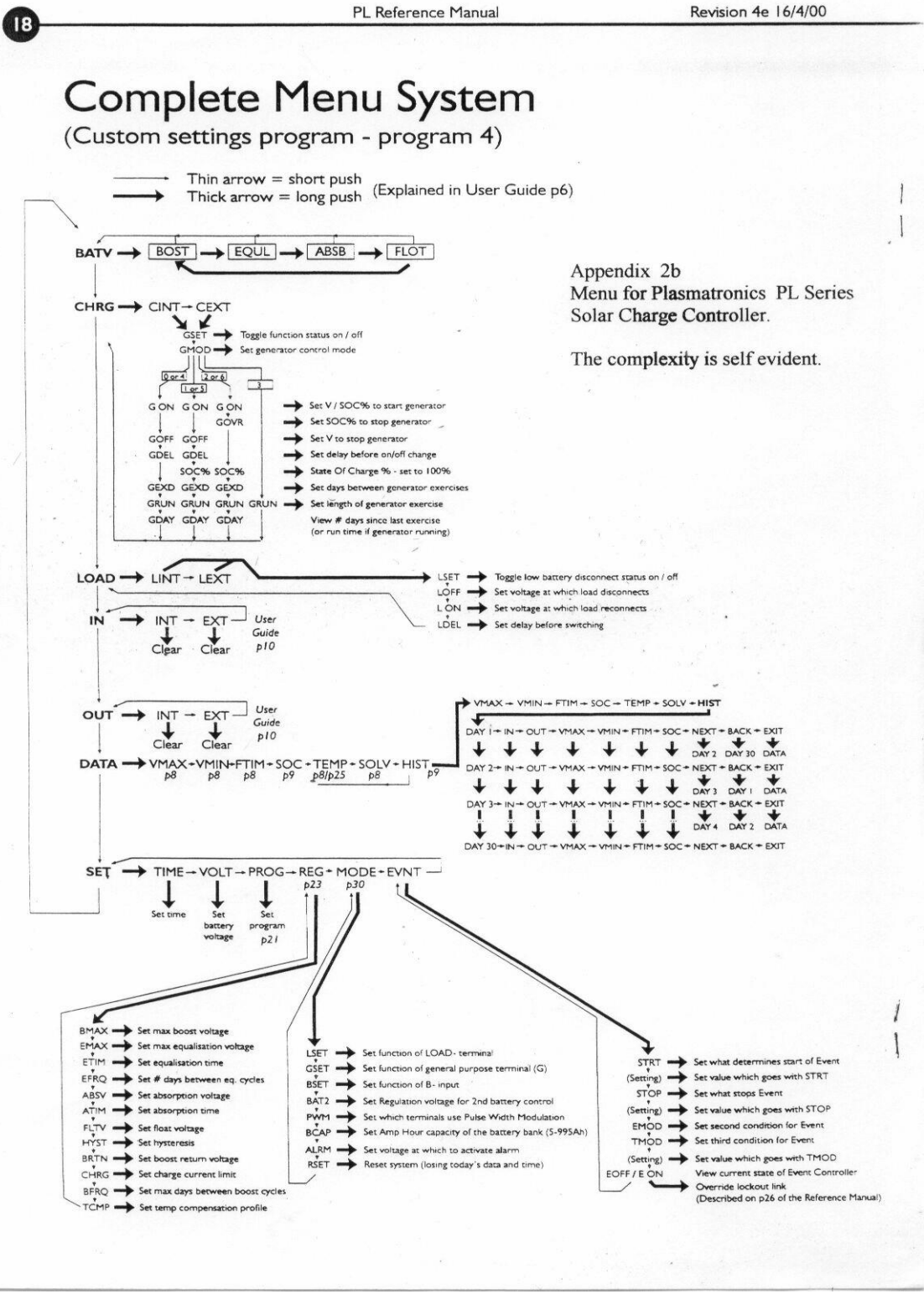
Screens in reverse are METER displays.

Values shown are the defaults at power-up and upon reset of the inverter.



5916 195th Northeast, Arlington VA 98223  
 TEL (360) 435-8826 FAX (360) 435-2229

# Appendix 6b Flow Chart for Plasmatronics Controller



Appendix 2b  
Menu for Plasmatronics PL Series  
Solar Charge Controller.  
The complexity is self evident.

**Map of the  
Daintree  
lowlands showing  
the locations of  
the subdivisions  
and the locations  
of the local  
districts.**

adapted from  
Brannock and Humphries  
1993

